

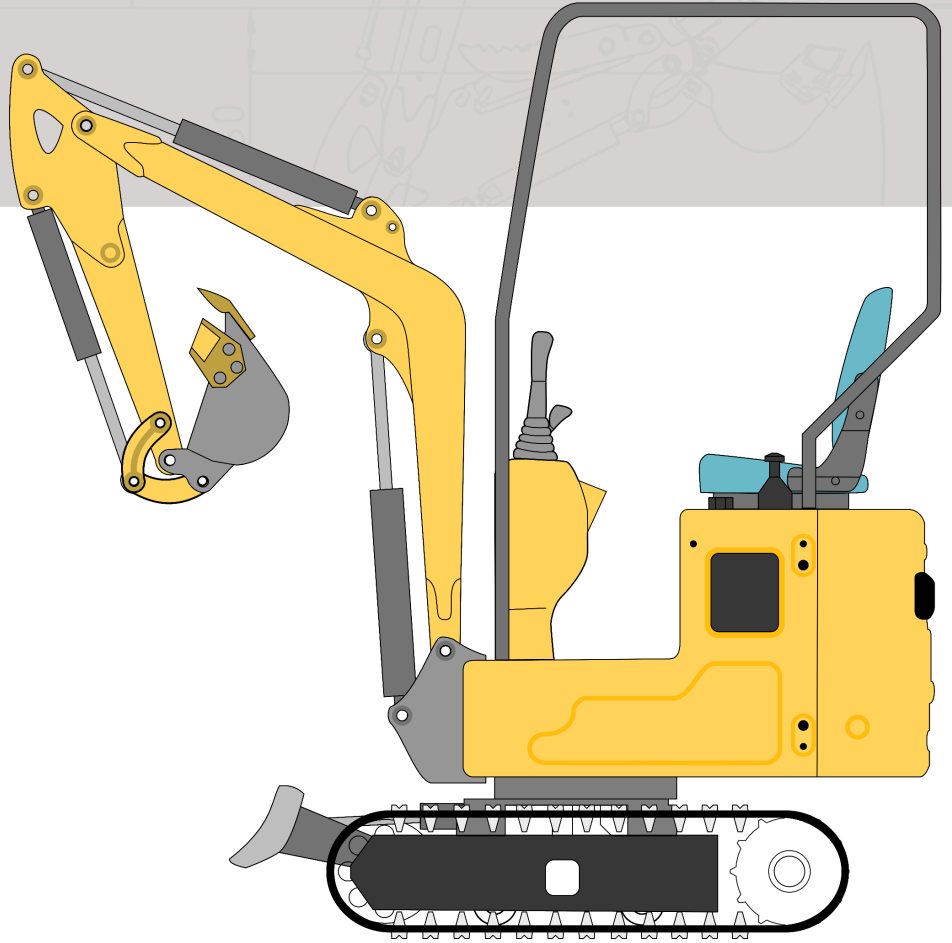

**EXCAV**  
US and Caribbean

## R319 Series User Manual

English  
US Compliance  
Revision: 14/AUG/2024



# TABLE OF CONTENT

TABLE OF CONTENT.....	2
SAFETY.....	5
General precautions.....	5
Preparing for a job.....	6
Precautions during operation.....	6
Precautions during maintenance.....	13
OPERATION.....	14
Before operating.....	15
Controls.....	16
Starting and stopping the engine.....	18
Starting the engine under cold weather.....	19
Starting with a booster.....	21
Stopping the engine.....	21
Operate travel levers.....	23
Operate the working equipment.....	25
Operate dozer blade and telescopic tracks.....	26
Operate optional tools.....	26
Other controls.....	28
Operating instructions.....	29
Lifting objects.....	30
Change dozer blade width.....	31
Replacing the bucket.....	32
Maintenance.....	33
Crawler track assembly components.....	34
Precautions with crawler rubber tracks.....	35
Inspection of tracks.....	36
Adjusting track tension.....	37
Replacing the crawler track.....	38
Lubrication.....	39
Inspection of hydraulic hoses.....	40
Checking the hydraulic oil tank level and replenishing.....	41
Electrical.....	41
Maintenance Schedule.....	43
APPENDIX: Engine XR Series 25T 13.5 HP.....	45
Changing the engine oil.....	46
Servicing the engine air filter.....	47
APPENDIX: Lift Capacities.....	48
APPENDIX: Lubricants and Fuels.....	48
APPENDIX: Consumables and Components.....	51
APPENDIX: Emissions Control.....	53
APPENDIX: Units of Measurements.....	55
APPENDIX: Torque Values.....	56





# Operator's Manual

Copyrights 2024

Created by EXCAV Caribbean  
Aguadilla, Puerto Rico, USA

# SAFETY

## General precautions

It is the responsibility of the operator to observe all pertinent laws and regulations and to follow the instructions on machine operation, inspection and maintenance.

 This image is the safety alert symbol. This symbol will appear in sections to alert the reader of important information regarding health hazards and operational hazards.

**Improper operation, inspection and maintenance of this machine can cause injury or fatalities.**

Local and Federal regulations pertinent to the safety and operation of this machine supersede the contents of this manual.

Understand and follow all safety rules and precautions when operating, inspecting, or performing maintenance.

Most accidents can be prevented by identifying the potentially hazardous situations beforehand.

Do not operate the machine until you are sure that you have gained a proper understanding of its operation, inspection and maintenance.

Be prepared for fires and accidents:

- Install a fire extinguisher and a first aid kit, and ensure you know how to use them.
- Learn how to extinguish fires and manage accidents properly.
- Keep emergency service contact information easily accessible.

Wear appropriate clothing and protective equipment.

Do not wear loose clothes or items that could become caught.

Do Not remove safety equipment except for servicing.

Repair or replace damaged safety parts before operating the machine.

## Preparing for a job

Before starting a job, learn the conditions of the job site to ensure safe operation.

Inspect the topography and ground condition of the working area, or the structure of the buildings, and take the safety precautions necessary.

When working on roads, be sure to consider the safety of pedestrians and vehicles. Fence the working area when possible. Use a flag person. Ensure a spotter is present to ensure a safe environment.

When working in water or crossing shallow streams or creeks, check the depth of the water, the solidity of the ground and the water flow speed beforehand.

Check the allowable load of bridges or other structures where the machine will operate.

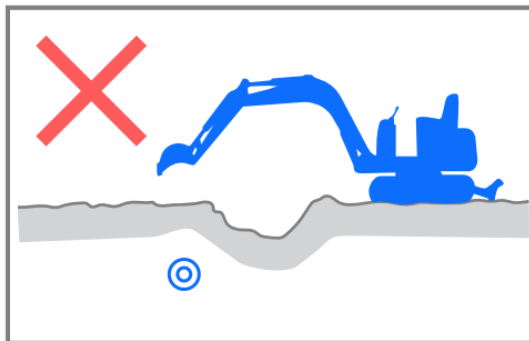

Buried utilities (water pipes, electrical lines, gas, communications) pose a risk of serious injuries, death or civil liabilities.

Contact authorities to determine the presence of underground pipes, cables prior to excavation.

Verify the location and depth of the buried utilities and mark buried utilities to maintain a safe distance from the utilities.

Know the utility color codes:

Blue = Water, Electric = Red, Communications = Orange, Gas = Yellow, Sewer = Green/Brown

Use a signal person to monitor the safe operation of the machine around utilities and power lines.

## Precautions during operation

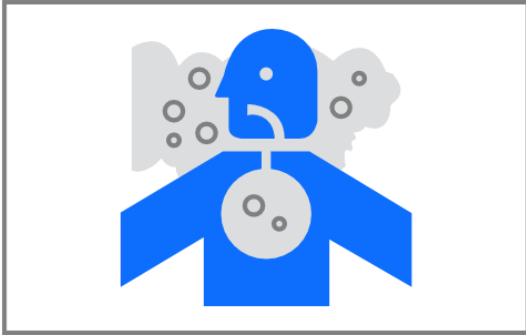

Exhaust gasses from the combustion engine can cause illness or kill.

Crushing, cutting or drilling concrete, aggregates and others may result in exposure to silica dust.

Operate the excavator on locations with proper ventilation or gear a respirator as required by the conditions.

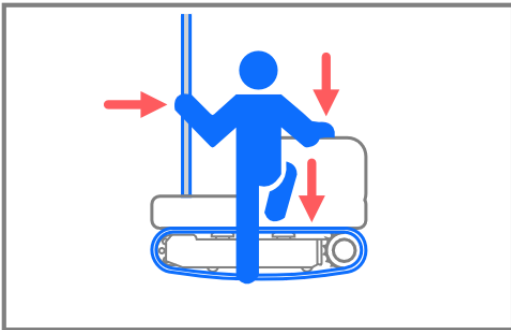

Use three points of contacts when getting on/off the machine.

Do not jump on or down from a moving machine.

Do not use any of the control levers as hand holds.

When working in dark places, turn on the machine's working lights and use additional lighting equipment as necessary.

When visibility is poor due to bad weather (fog, snow, rain or dust), or other conditions stop operating the machine and wait until visibility improves.

Never allow anyone to enter the machine's slewing radius and travel path.

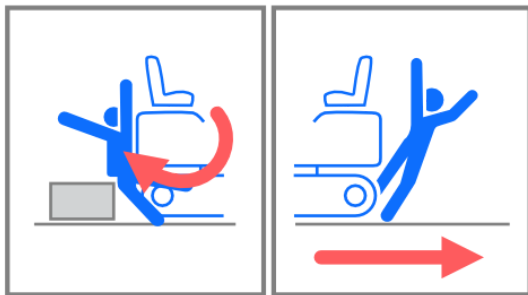

Ensure there is room for the swing radius and bucket operation.

Ensure there are no obstructions or working people in the swing radius or travel path.

Use a spotter when working around overhead lines, underground utilities, road shoulders, in tight working conditions, or when the field of the view is obstructed.



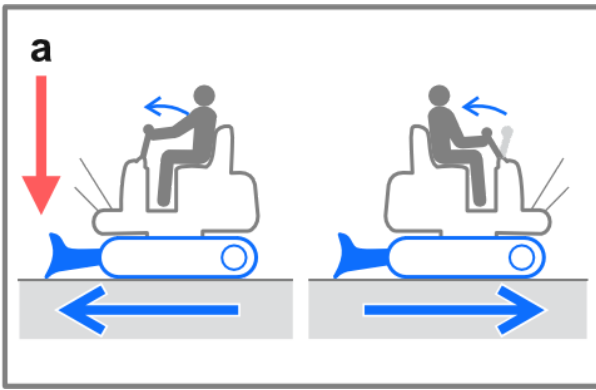

Before operating the travel levers, make sure to notice the location of the dozer blade (a).

Remember that when the dozer blade (a) is to the rear of the operator's seat, the travel levers must be operated in the reverse direction from when it is to the front.

Be aware of blind spots while operating the machine.

Before traveling in reverse, check that the area is safe and clear.

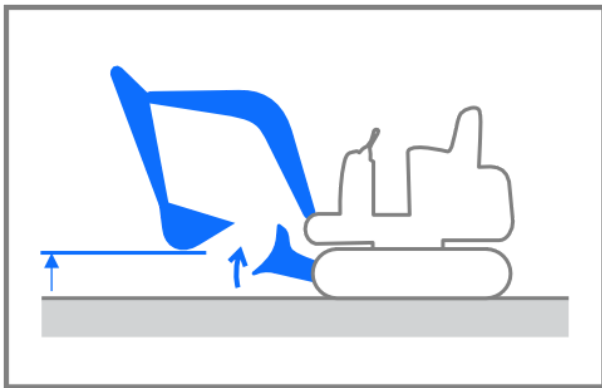

Travel with the dozer blade raised, the boom arm folded as shown on the figure, and the bucket raised 12 to 16 in (30 to 40 cm) above the ground.

When equipped, travel with extensible tracks extended whenever possible.

Do not slew while traveling. If you must operate the hoe attachment while traveling, operate at speeds slow enough so you have complete control at all times.

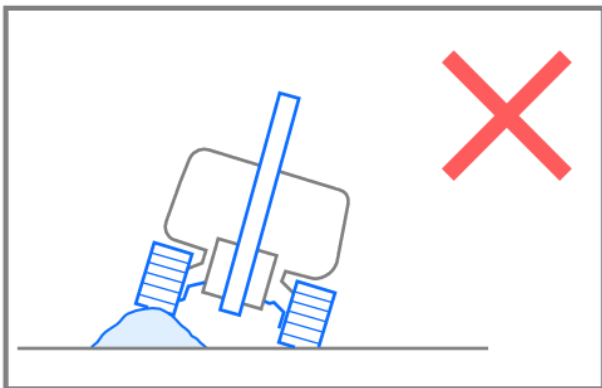

Avoid crossing over obstacles whenever possible. If you must do so, keep the hoe attachment close to the ground level and travel slowly.

Never cross obstacles which will tilt the machine to an angle of 10° or greater.

Go slow on uneven surfaces and avoid sudden starts, stops or changes of direction.

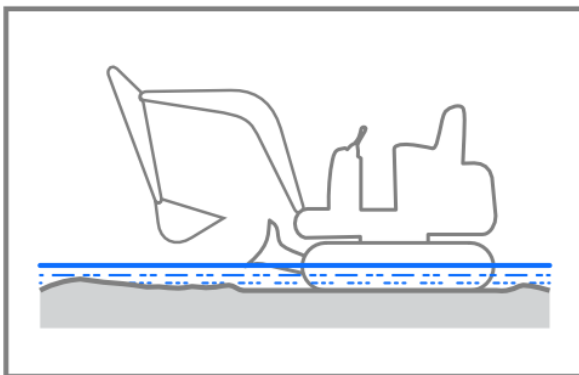

You may briefly submerge the machine when the water level will stay below the middle of the crawler side.

Never submerge the slew bearing or main body in water or sand.

The machine WILL require maintenance after parts are submerged or exposed to water.

When operating on slopes or grades, slewing or operation of working equipment may cause the machine to lose stability and tip over.

Avoid operating on slopes whenever possible.

When climbing or descending a slope, drive slowly and keep the operator's seat facing the direction of travel.

Never travel down a slope that exceeds 17°.

Lower the bucket to a height of 8 to 12 inches (20 to 30 cm) above the ground. Adjust the reach of the bucket to balance the machine. Use the bucket to stop the machine in case of an emergency.

When traversing down a slope keep the dozer blade (a) uphill to better balance the machine and prevent detracking.

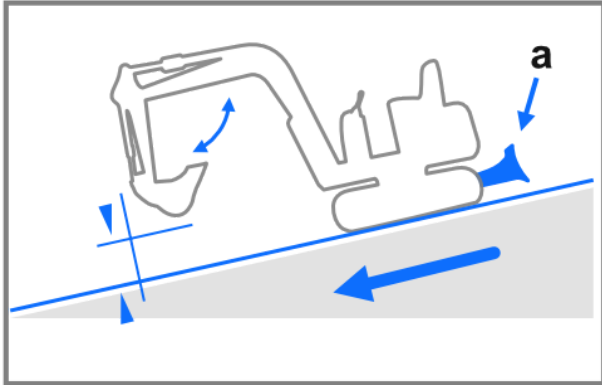

When climbing a slope, extend the bucket to the front and lower the bucket to a height of 8 to 12 inches (20 to 30 cm) above the ground. Adjust the reach of the bucket to balance the machine. Use the bucket to stop the machine in case of an emergency.

Never travel up a slope that exceeds 15° of incline.

Always travel perpendicular to the slope. Do not change directions while traveling on a slope.

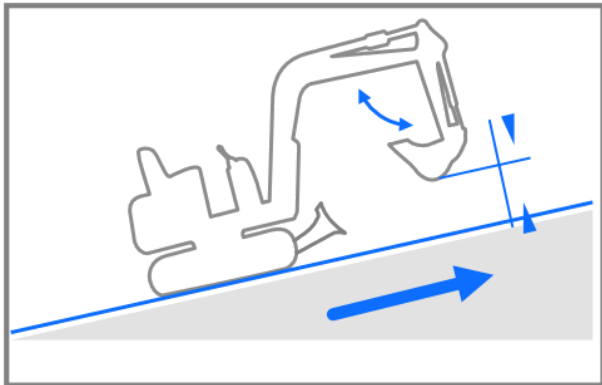

Avoid slewing to the downhill direction in particular if you have a load in the bucket.

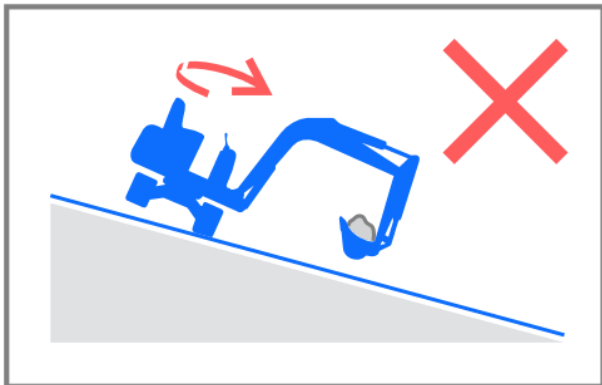

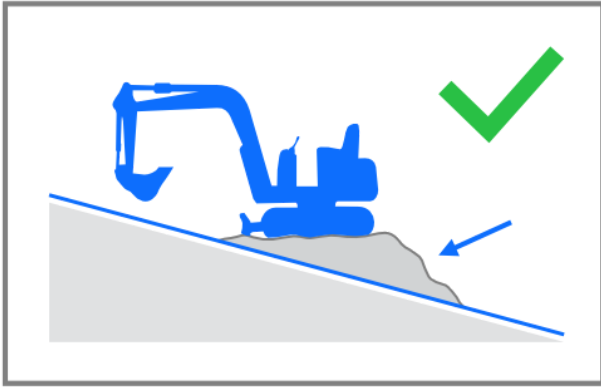

Level off the working area to maintain the machine as horizontal as possible. Ensure that the ground is stable.

Prolong operation on slopes of over 15° will reduce the engine life and may damage the machine prematurely.

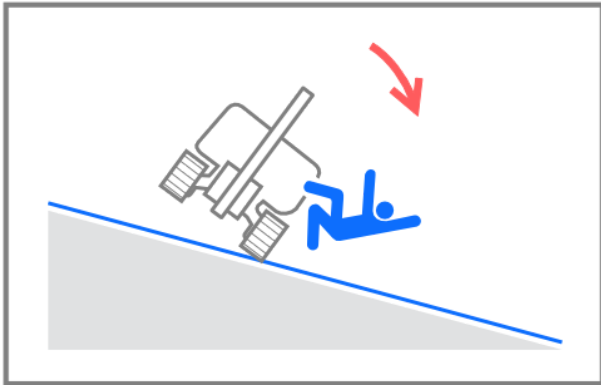

The lateral tipping angle is 10°. (Note that the machine's stability varies by the actual working condition.)

Do not traverse slopes or change directions on slopes. First return to a flat surface, and then take an alternative path.

The machine may slip sideways even on a slight slope if the ground is covered with grass, leaves, or when wet or frozen.

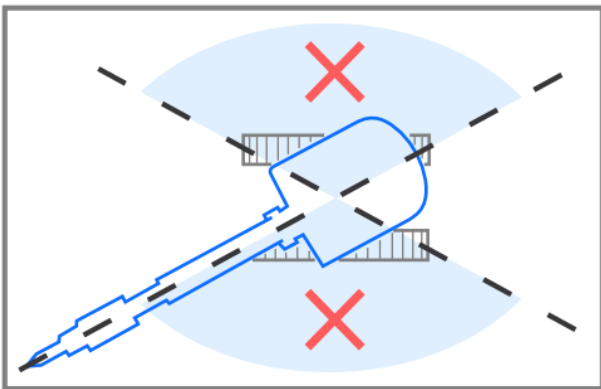

The machine is more vulnerable to rollover in the lateral direction than longitudinal direction.

Do not swing the boom laterally when the bucket is heavily loaded.

Remember that attachments like a breaking hammer or others are heavier than the standard bucket.

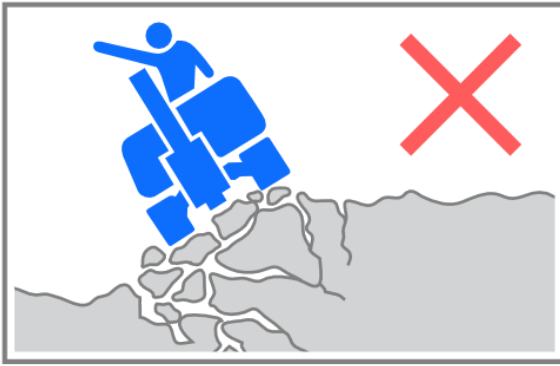

Approach overhangs, cliffs and edges of ditches carefully as they could cave in.

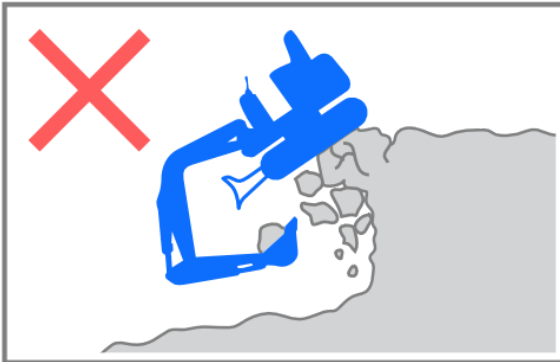

Maintain a safe distance between the machine and the edge of the digging site.

Do not dig the ground under the machine.

Set the crawlers parallel to the edge of cliff or road shoulder and the dozer blade to the front to allow for an easier escape.

Do not perform demolition under or above the machine.

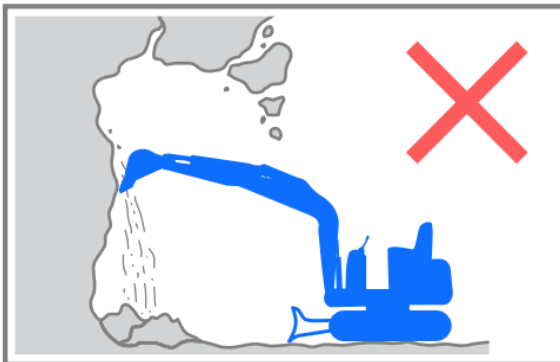

Never undercut a high bank.

Do not operate in places where there is a danger of falling rocks.



Do not operate on areas where there is soft ground as it may cause the machine to tilt under its own weight, resulting in a machine tipping over or sinking into the ground.

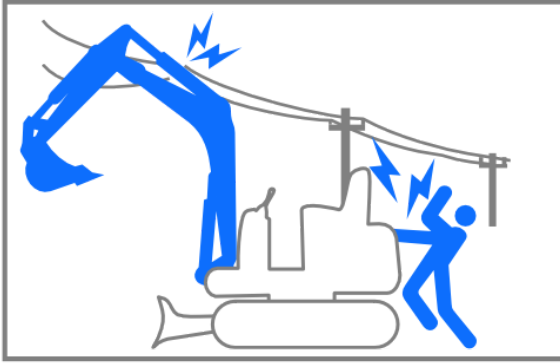

Keep a safe distance from the overhead electrical and utility cables.

Consult with local authorities for requirements operating near power lines.

Maintain a minimum of 10 feet from power distribution lines up to 50kV. Consult with the local power company for work near high voltage transmission lines.

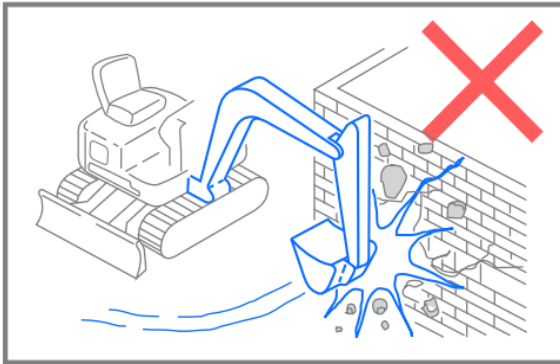

This machine is not equipped with an adequate protective structure to safeguard the operator from falling objects or projectiles.

Do not use the arm or attachment to ram structures as it may cause serious injuries to the operator and damage the machine.



Do not move loads above people.

This machine is not designed for lifting. Extreme caution should be paid if the excavator is used for lifting.

Overloading will cause the machine to roll and can result in serious injury or death.

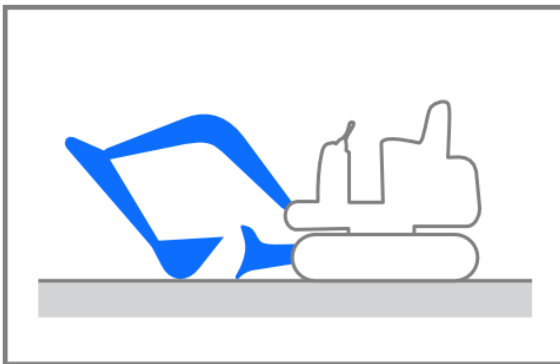

Park the machine on a flat, rigid and safe ground. Set the parking brake.

When parking on a street, use barriers, caution signs, lights, etc., so that the machine can easily be seen even at night.

Before leaving the operator's seat, lower the excavator arm to the ground, engage the hydraulic lock (if equipped), stop the engine and remove the key.

## Precautions during maintenance

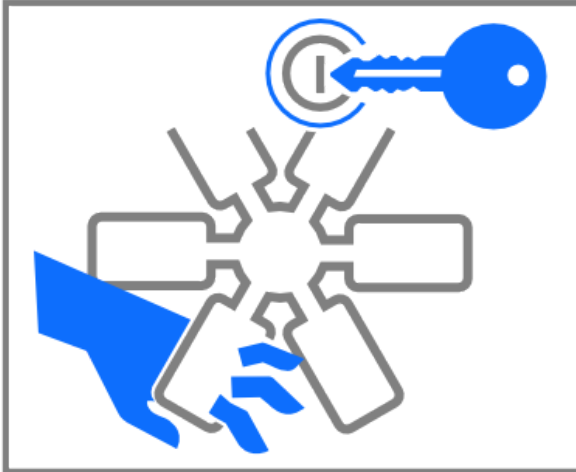

Ensure that the machine can not be accidentally operated while servicing the machine.

Stop the engine before performing maintenance.

Avoid lubrication or mechanical adjustments while the machine is moving or while the engine is running.

Stay clear of all rotating and moving parts.

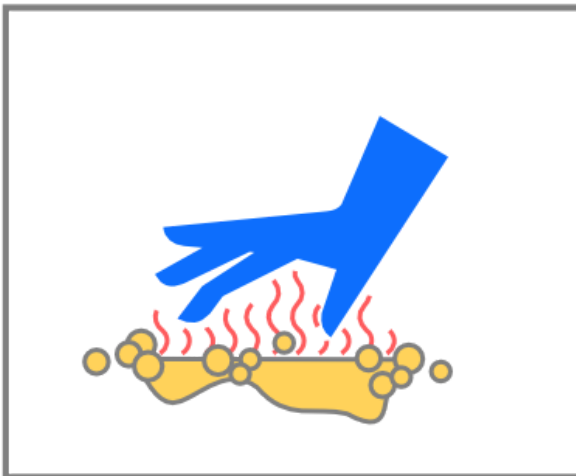

Hydraulic oil, engine and other components remain hot after the machine is turned off. Allow the machine to cool down to avoid risk of burns.

Follow appropriate laws and regulations when disposing of harmful objects such as oil, fuel, coolant, solvent, filters and batteries.

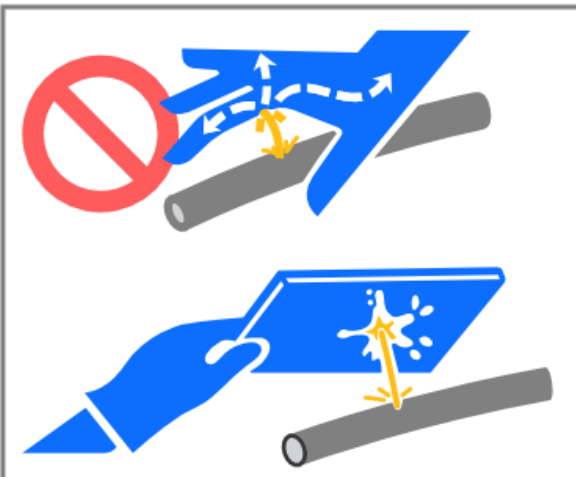

Pressure is maintained in the hydraulic lines long after the engine has been shut down.

Completely relieve the internal pressure before performing maintenance work. Stand to the side when removing plugs or screws on the hydraulic system.

The mist of hydraulic oil leaks is almost invisible. When checking for leaks, wear protective goggles, thick gloves, and protect your skin from oil spurting.

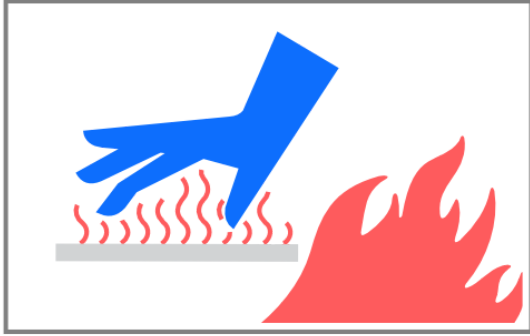

All fuels and most lubricants are flammable. Flammable fluids that are leaking or spilled onto hot surfaces or onto electrical components can cause a fire. Do not wear clothing soiled with fuel or other flammable substances.

Fuel and its vapors are flammable and explosive.

Engine and other components operate at high temperatures.

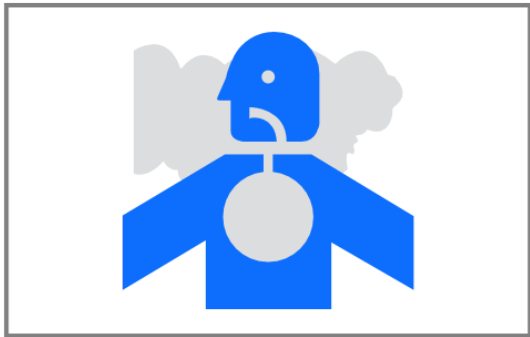

Exhaust gasses from the combustion engine can cause illness or kill.

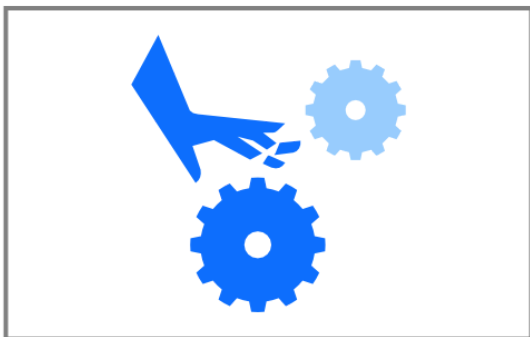

Rotating parts can entangle hands, feet, hair, clothing, or accessories and result in traumatic amputation or laceration.

Operate machine with panels and the guards correctly installed.

Keep hands and feet away from moving parts.

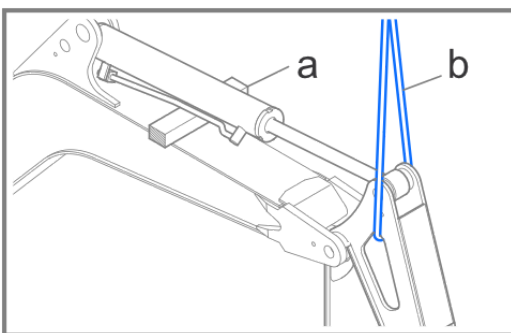

When the pump is not operating the machine may lose hydraulic pressure unexpectedly. To prevent unexpected movement and accidents, firmly secure the working equipment when working on the bucket, arm or boom.

Immobilize cylinders with a block (a) and support (b) the arm/boom to prevent accidents when hydraulic pressure is lost.

# OPERATION

## Before operating



Perform the daily walk around inspection once a day before starting the engine for the first time.

Before starting the engine, look around the machine and clean any combustibles from the surroundings of the engine. Also, inspect if oil is leaking and if any nuts or bolts are loosened.

Check for any twigs, leaves, oil or other combustible materials around the engine and battery.

Check for oil leakage from the hydraulic tank, hydraulic devices, hoses or connections.

Check the crawlers, shoe slides, track rollers, idlers and sprockets for damage, wear and loose bolts. Remove rocks and excessive dirt from tracks.

Check the bucket, bucket teeth and side cutter for wear, damage and looseness.

Perform lubrication, maintenance or repairs as required before operating the machine Refer to the MAINTENANCE section for actions required before using the machine.

If any problem (noise, vibration, smell, disorder of instrument, smoke, oil leak or wrong indication of alarm and panel, etc.) is detected during the inspection or operation and maintenance of the machine, DO NOT operate the machine until the issue is corrected.



## Controls



Do not operate the machine until the operator is familiar with the function and location of the machine controls.

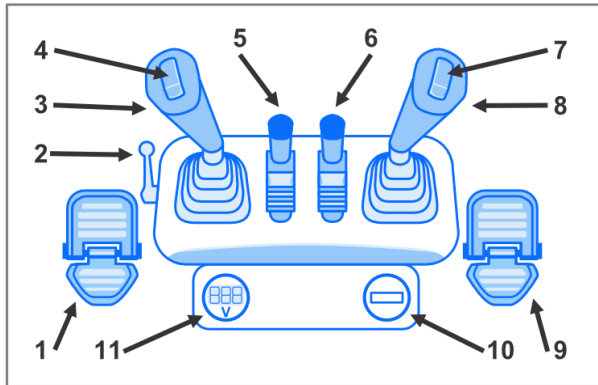

The main operating controls are located on the central console:

1. Left pedal, dozer blade & telescopic tracks.
2. Hydraulic lock (optional).
3. Left control joystick.
4. Button, Change left joystick operation.
5. Left travel lever.
6. Right travel lever.
7. Button, Horn or to Change left pedal operation.
8. Right control joystick.
9. Right pedal, auxiliary tool.
10. Hour meter (optional).
11. Voltage meter (optional).

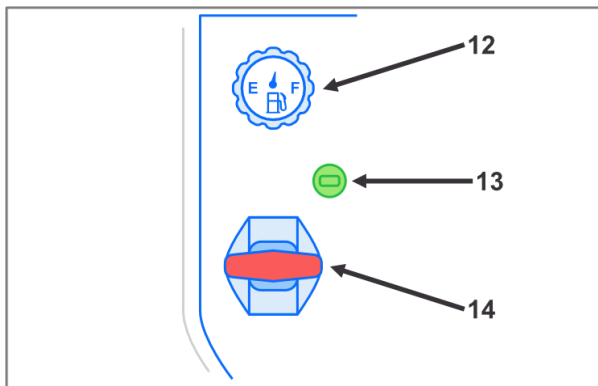

Instruments on the left side of the operator:

12. Fuel gauge (optional).
13. Voltage meter (optional configuration).
14. Battery disconnect switch.

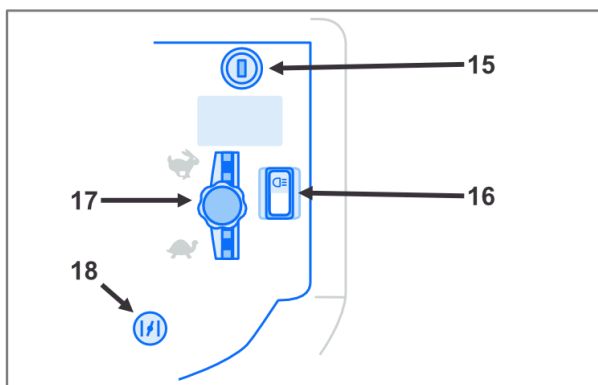

Instruments on the right side of the operator for 2023 models:

15. Engine ignition key.
16. Switch, working boom lights.
17. Engine throttle lever.
18. Engine choke lever.

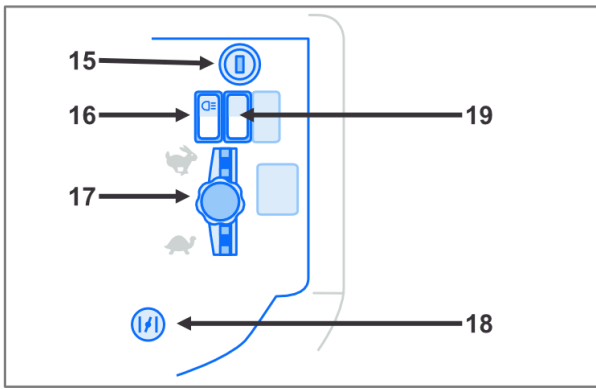

Instruments on the right side of the operator for 2024 models:

- 15. Engine ignition key.
- 16. Switch, working lamp.
- 17. Engine throttle lever.
- 18. Engine choke lever.
- 19. Switch, operate optional tool.

## Starting and stopping the engine



Before starting the machine ensure the area is clear of people and hazards.

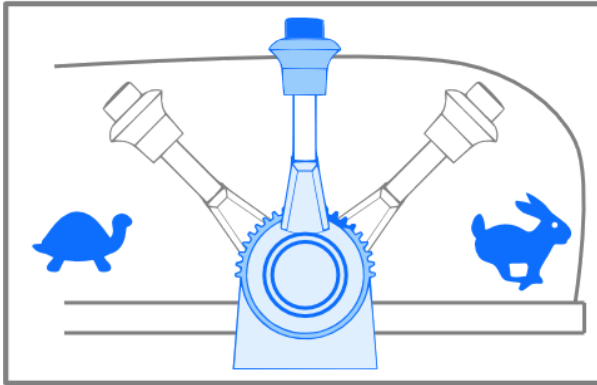

Press and pull the knob up to unlock the throttle (14).

Move the lever back to lower the throttle. Move the lever forward to increase the throttle.

Under normal conditions the throttle should be set in the middle, adjust throttle as required by the loads.

Do not use full throttle for prolonged periods of time. Higher throttle may cause movements of the machine to be more jerky.

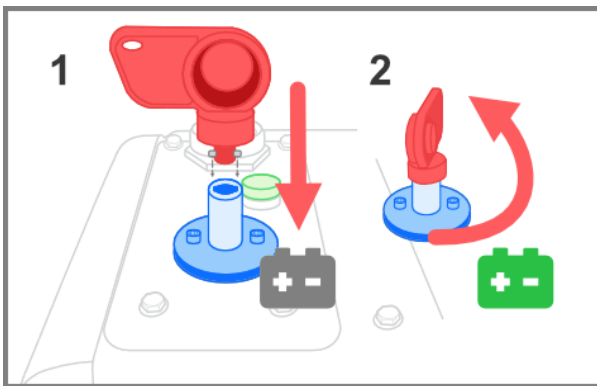

The battery cut-off switch disconnects or connects the machine's electronics from the battery.

Insert plastic key by aligning the pins with corresponding slots on the switch base.

Turn the lever 90 degrees to lock the key and engage the battery.

When not using the machine remove the key and replace the plastic cover.

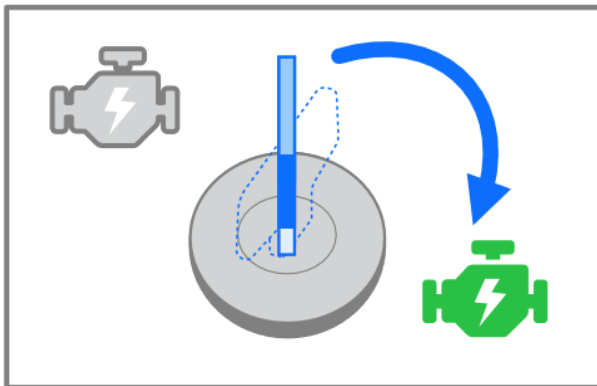

Pull the choke lever (11) half way up or higher as required.

Put the throttle lever backward to slow speed.

Turn the key right and release after the engine has started. (*Pause 20 seconds before attempting a consecutive start.*)

Return choke (11) to original position.

Set the throttle to the middle position.

Allow the machine to run for at least 5 minutes to warm up the hydraulic oil.

**NOTICE:** If the engine stalls due to running out of fuel the choke must be adjusted to start the engine. Additional turns of the key may be required to allow the crankcase to build vacuum and pull the fuel into the carburetor. Check that the engine fuel shut-off lever is in the open position.

## Starting the engine under cold weather



Make sure to read the respective section on engine and hydraulics for proper selection of fuel, engine oil and hydraulic oil as required by cold conditions.



Do not use starting fluids or other flammable fluids on the engine to attempt to start the engine.



Do not operate the machine if the temperature of the hydraulic oil is below 68°F. Heat up the machine until hydraulic oil temperature reaches at least 68°F.



Refer to the section APPENDIX: LUBRICANTS AND FUELS for the proper selection of fuel and lubricants in cold weather.



Check the engine battery to ensure acid is not frozen. If suspected of a frozen battery, it must be heated up to restore the acid liquidity.

Check the battery voltage and charge battery if required. If the battery is discharged (but not frozen) a battery booster can be used to jump start the machine.

Do not charge or jump start a frozen battery. Do not run the machine with a frozen battery.

A battery heating pad may be used.

See section Starting with Booster for more information on how to jump start the machine.

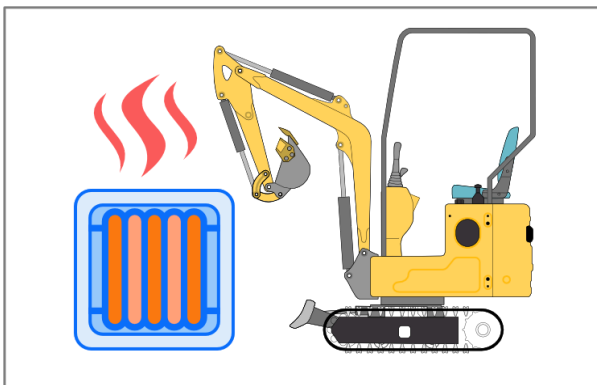

The engine oil, fuel and hydraulic oil may freeze. Check fuel and oils before starting the machine.

Heat the engine compartment and machine before starting the machine. If fuel or oil is suspected of freezing the machine must be heated for a longer period of time.

Consider moving the machine out of the weather to improve the warming up of fluids and engine block.

Do not do continuous attempts to start the machine as the battery voltage drops faster in cold weather. Wait at least 20 seconds between start attempts.

If the machine is not starting, allow more time to further

warm the machine.

If the machine is expected to be operated frequently under cold weather consider storing the machine in a warmer location.

## Starting with a booster



Do not charge or jump start a frozen battery.



Do not let the terminal clips of the jumper cables touch each other.



When using a booster or battery charger make sure to match the charging current to the battery's specifications.

Ensure that the rescue battery or booster has the same 12V voltage and provide at least 300 amps for cranking.

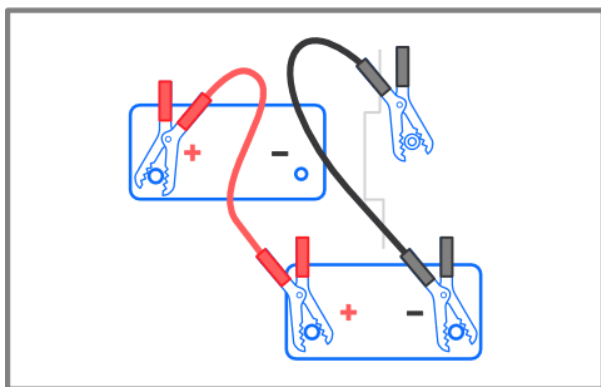

Connect one jumper cable to the positive terminals of the rescue battery and the machine's battery.

Connect the other jumper cable to the negative terminal on the rescue battery and the other end to the chassis or engine block of the machine. Ensure that the negative jumper clip is making good contact with the machine chassis.

Leave the batteries connected for 5 minutes.

Start the engine.

Disconnect the jumper cables in reverse order, starting with the jumper clip connected to the machine chassis.

## Stopping the engine



Do not stop the engine while carrying loads or leave the bucket in the air. The hydraulic system WILL lose its pressure and may cause an accident or damage the machine.



Stop the machine on firm and level ground. See section on Operating Procedures for more information on stopping and parking the machine on slopes.

Lower the bucket and the dozer blade to the ground.

Set the throttle to its slowest setting. Idle the engine at this speed for about 5 minutes to allow it to cool down.

Turn the starter key off.

Disconnect the battery cut-off switch and turn off appliances that may be running off the battery.

Remove the key to prevent unauthorized use of the machine.

## Operate travel levers



Before operating the travel levers, make sure that the dozer blade is to the front of the operator's seat. When the dozer blade is to the rear of the operator's seat, the travel levers must be operated in the opposite direction.



An unexpected driving direction could lead to accidents resulting in serious injury or death. Always check the driving direction before moving the machine. When making turns, be sure nobody is standing within the swing area of the excavator.



When making turns, be sure nobody is standing within the swing area of the machine.

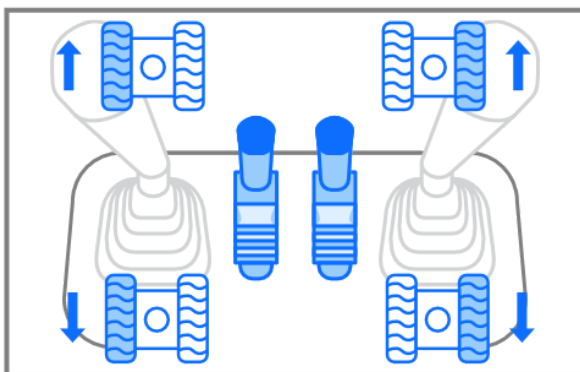

The two center levers (5)(6) control the travel direction of the crawler. Each lever controls a crawler track on one side of the machine.

When the lever is at its neutral position the corresponding crawler track will not move.

To move forward, push both drive levers simultaneously. Releasing the drive levers stops the machine. To move backwards pull the two levers simultaneously.

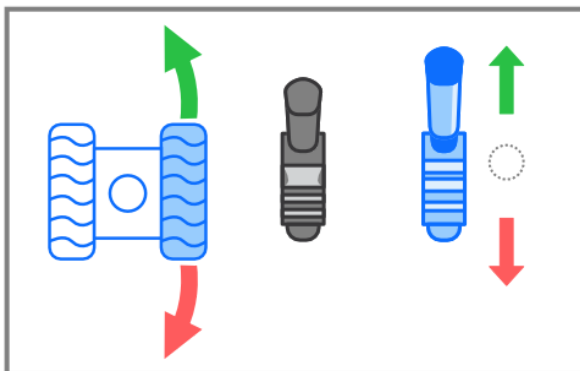

### PIVOT TURNS

To turn left bring the left lever (5) to neutral and the right lever (6) forward. To turn right do the opposite: bring the right lever (6) to neutral and the left lever (5) forward.

To turn backward in the opposite direction pull the corresponding lever backward.

**Changing direction on steep slopes may cause the machine to tip over.**

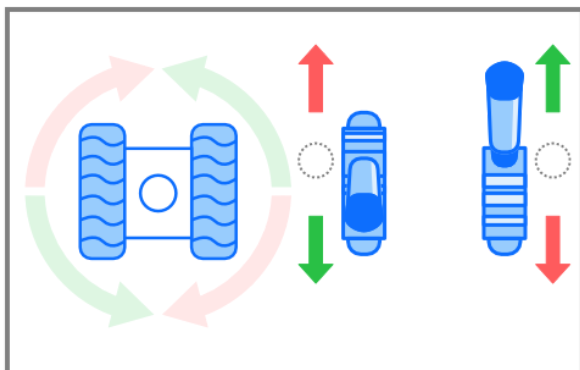

### SPIN TURNS

When both drive levers are activated in the opposite directions, both tracks will rotate with the same speed but in opposite directions. The center of rotation is the center of the excavator.

To spin left push the left lever (5) backward and the right lever (6) forward.

To spin right, push the right lever (6) backward and the left lever (5) forward.





## Operate the working equipment



This machine is configured from the factory with an ISO 10968 control pattern.

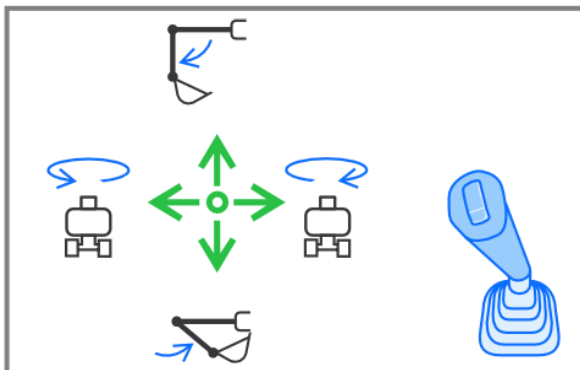

Moving the left joystick (3) horizontally from left to right rotates the machine.

Move the joystick left to slew the machine left and right to slew the machine right.

Moving the left joystick (3) vertically from top to bottom extends or contracts the arm.

Move the joystick up to extend the arm and down to contract the arm.

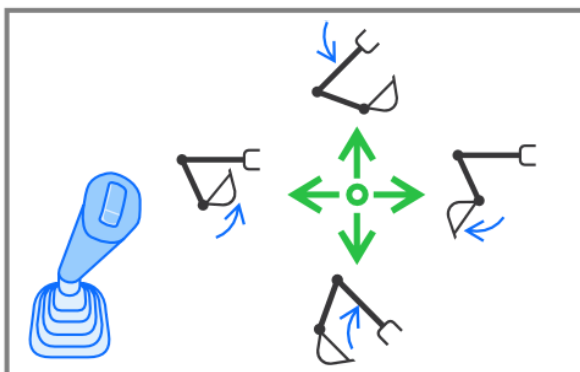

Moving the right joystick (8) horizontally from left to right curls or dumps the bucket.

Move the joystick left to curl the bucket in and right to flip the bucket outward.

Moving the right joystick (8) vertically from top to bottom lowers or raises the boom.

Move the joystick up to lower the boom and down to raise the boom.

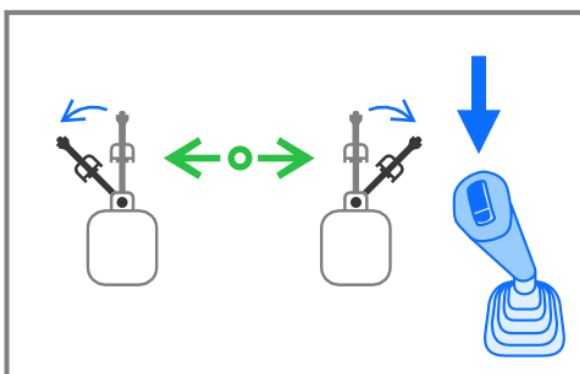

Press and hold the left joystick button (4) to swivel the boom.

While pressing the button (4) move the joystick (3) horizontally to swivel the boom from left to right.

Release the button (4) to return to the original operation and control the undercarriage swing.

Use this option to position the boom at an offset from the center to dig closer to walls and structures.

## Operate dozer blade and telescopic tracks

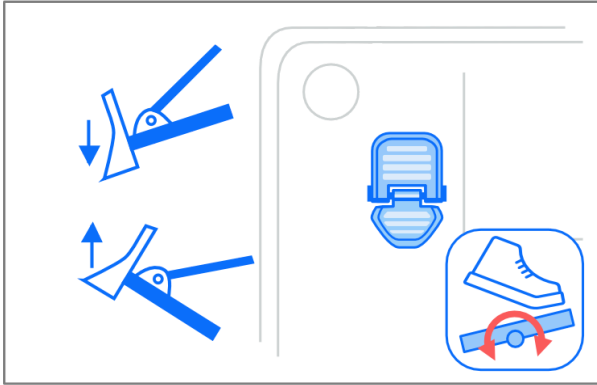

The left pedal (1) controls the height of the dozer blade. To operate, step on the pedal to rock the pedal down or up.

Step on the top side of the pedal to lower the dozer blade.

Step on the bottom side of the pedal to raise the dozer blade.

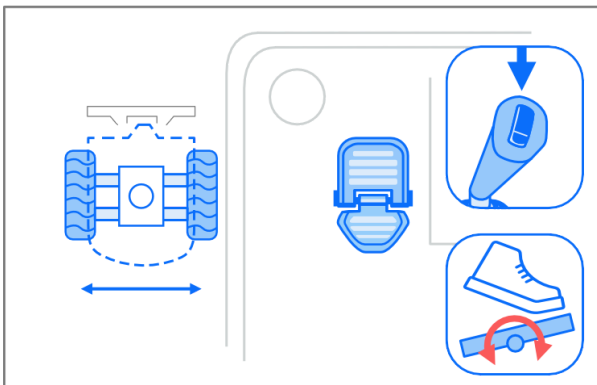

On machines equipped with telescopic tracks the left pedal (1) is also used to expand or retract the tracks.

Press and hold the button (7) on the right joystick (8). The right pedal will operate the telescopic tracks while the button (7) is pressed.

Release the button (7) to return to the original operation of the pedal.

Adjust the width of the telescopic tracks only in firm and stable ground without obstacles.

## Operate optional tools

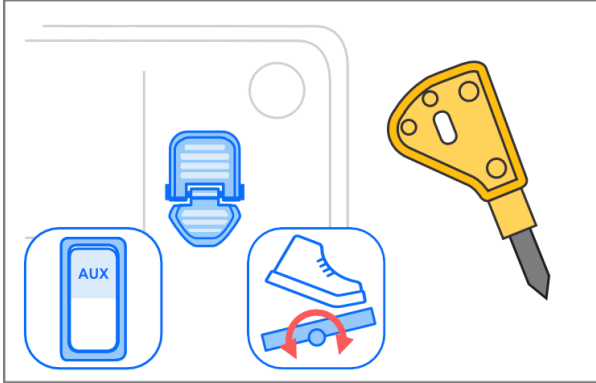

The right pedal (9) controls an auxiliary tool (thumb, hammer, etc) when equipped. To operate, enable the aux tool using the on or off switch on the side panel. Step on the pedal to rock the pedal down or up.

Step on the top side of the pedal to send the flow of hydraulic fluid to Port A.

Step on the bottom side of the pedal to send the flow of hydraulic fluid to Port B.

See section Auxiliary Hydraulic Lines for more information.

## Other controls

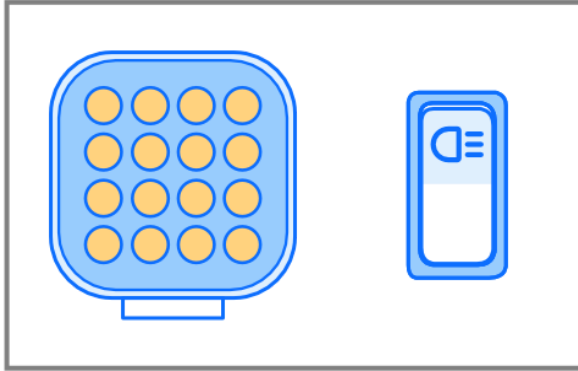

The machine is equipped with a LED working light located on the boom.

To turn the light on or off use the switch (16) on the right side of the operator's seat.

# Operating instructions



## Lifting objects



This machine is primarily intended for bucket operations. Improper use could cause serious machine damage.



Refer to the Load Capacity Chart on this document to understand capabilities of the machine.



Risk of crushing. Do not stand under a suspended load. Use appropriate loading and lifting equipment.



Only perform lifting operations on firm and level ground.

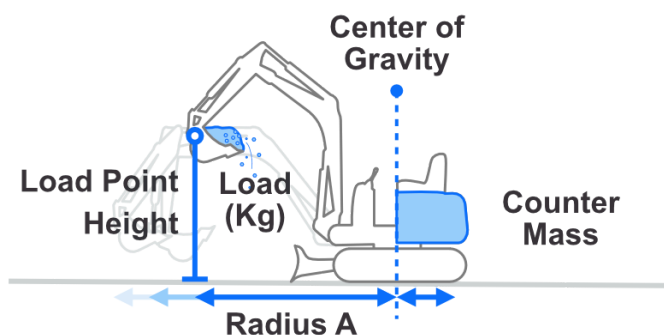

The lift capacity chart allows you to determine three important values. The Load (in Kg) is the weight allowed to be lifted up to the Load Point Height with the working piece at the distance given in Radius A.

The load point height and distance of the bucket to the machine's center of gravity dictates the weight (load) that you can lift to that height.

Before lifting a load the operator must determine if the machine is capable of safely lifting the load, how high can it be lifted and at what distance (Radius) the bucket must be to avoid exceeding the tipping point.

Lifting capacities are 75% of the tipping load or 87% of the hydraulic limit.

Lifting loads over the sides are limited to half the weight of loads allowed to be lifted on the front.

## Change dozer blade width

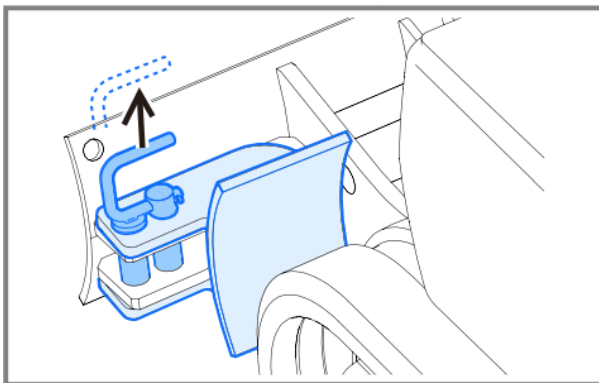

(A foldable dozer blade is optional equipment.)

Pull out the lock pin.

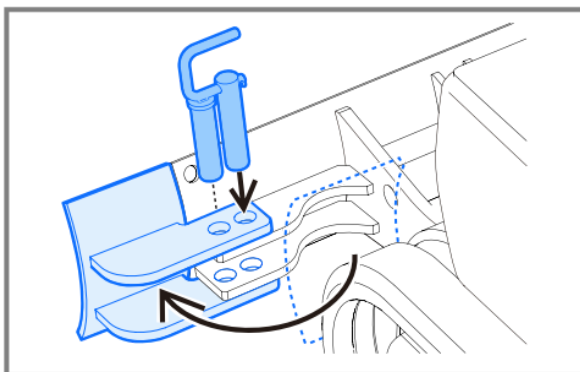

Rotate the blade outward.

Insert the lock pin to secure the blade



## Replacing the bucket

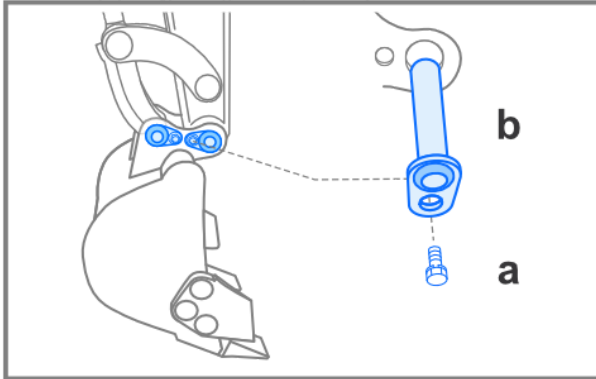

Lower the bucket to the ground at a slight angle with the edge pointing to the ground. The bucket should barely touch the ground. Adjust the height of the arm to reduce force on pins.

Remove the screw (a) securing the pin (b). Remove the pin (b).

Remove the bucket.

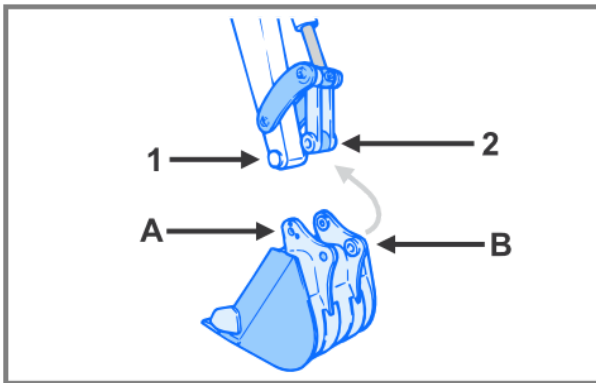

Align the pin hole (A) on the bucket with the pin hole on the arm (1), and install the pin.

Operate the cylinder, align the pin hole (B) on the bucket with the pin hole on the link arm (2), and install the pin.

Install the lock pins.

# Maintenance

## Crawler track assembly components

The idler wheel (A) holds the track on the other end. The idler pushes outward adding the required tension to hold the track in place.

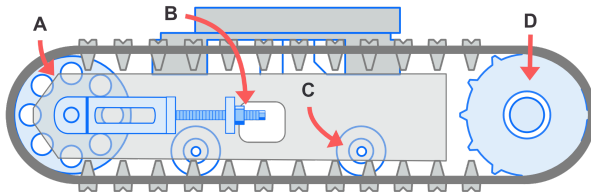

The idler is pushed by a tensioner (B) screw, some models may use a grease cylinder.

The two bottom track rollers (C) keep the track aligned and provide structural support.

The drive sprocket (D) is powered by the hydraulic travel motors. The sprocket is attached to the hydraulic motor's shaft with a cotter pin and castle nut.

## Precautions with crawler rubber tracks

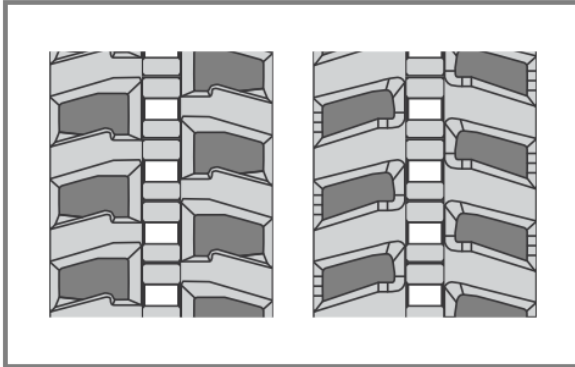

Use the correct type of track according to the expected operation.

A staggered block pattern track is a general purpose track designed to reduce disruption of soil and lawns while having an acceptable performance on sand, clay, dirt, mud, gravel, and asphalt.

A V shape pattern track provides better traction in muddy and soft dirt. The v-shape pattern moves the mud to the outside and thus it must be mounted facing forward.

Fuels and lubricants will damage rubber tracks.

Extended exposure to the sun (UV) will cause rubber tracks to degrade faster.

Continuous operation on rocks, hard surfaces or sharp debris will dramatically reduce the lifespan of the tracks.

Do not let the sides of the rubber tracks rub against hard surfaces or hold the weight of the machine.

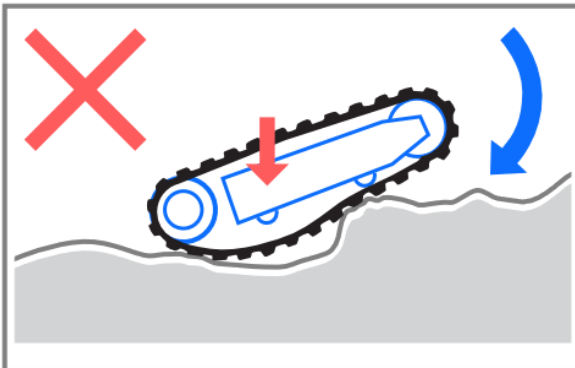

Traversing “step” like obstacles of over 8 in (20cm) creates a sag on the track that may cause the tracks to come off.

Move over obstacles one at the time slowly.

Do not change directions while there is slack on the rubber tracks, for example at angles or when a portion of the track is not supported.

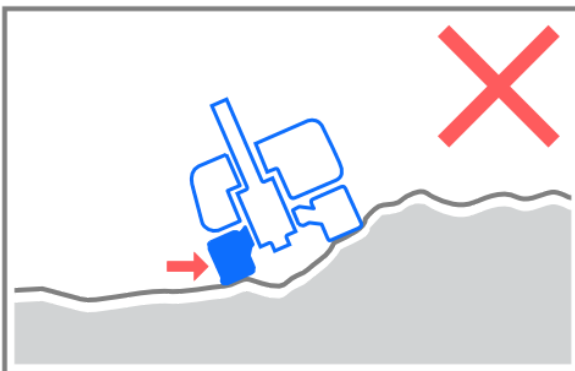

Avoid traveling with one crawler unevenly supported. This will damage the rubber track and/or may cause the track to come off. Chances of the crawler track coming off increases when traveling at an angle along a slope.

The crawler tracks will come off when traveling backwards and the crawler track is no longer in alignment and properly supported by the rollers.

## Inspection of tracks

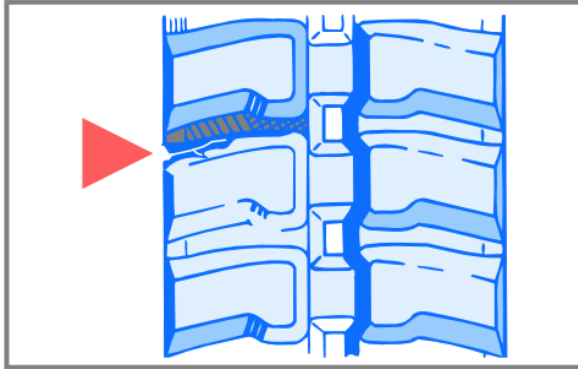

Remove lodge rocks and excess dirt from tracks.

Remove any lubricants or fuel from the track surface immediately.

Replace if there are cracks of 3 in. (60 mm) or greater in length.

Replace if even one of the inner metal cores (lug) is off.

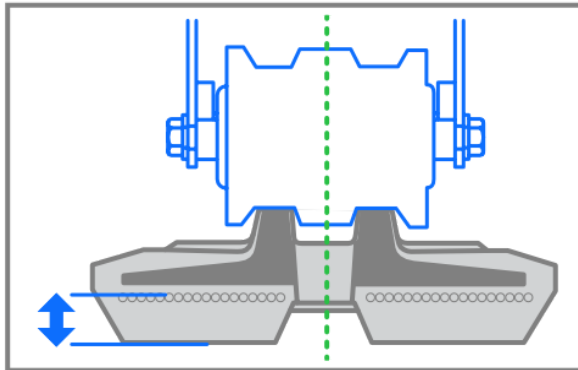

Replace if the height of the rubber sole is 1/4in or less (5 mm).

The track is reinforced with steel wires. Replace if the steel wires are exposed in two consecutive links or more.

Replace if the half or more of the steel cords on one side are cut.

Ensure the tracks are always aligned with rollers and idler wheel.

## Adjusting track tension

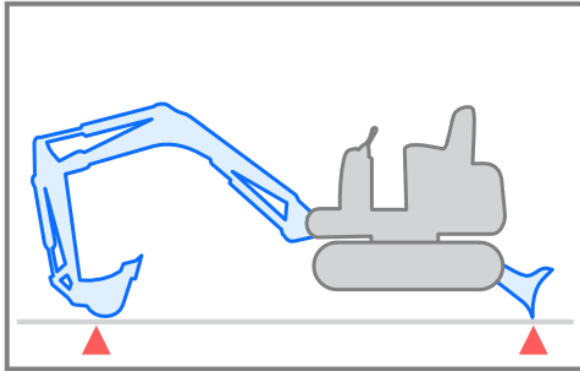

Park the machine on horizontal ground.

Lower the dozer blade in the back to the ground until the tracks are slightly raised.

Lower the bucket to the ground, operate the boom until the machine is raised.

Run the tracks several times in forward and reverse.

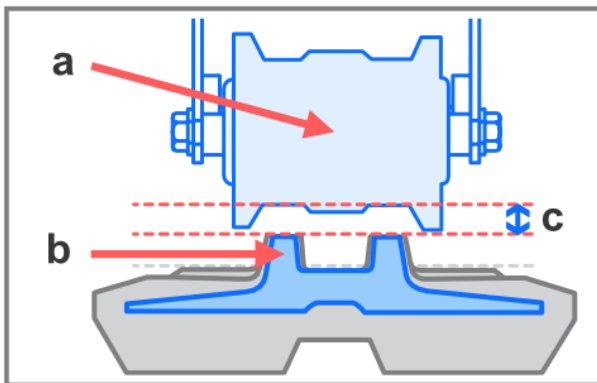

The rubber track is correctly tensioned when the distance (c) between the track roller (a) and the top of the iron log guides (b) is 15mm to 25mm (1 inch).

With proper tension the iron lugs guides (b) will remain within a distance that is less or equal to the height of the iron log guides (b).

Incorrect tension reduces the lifetime of the tracks. A too low track tension increases the risk of detracking.

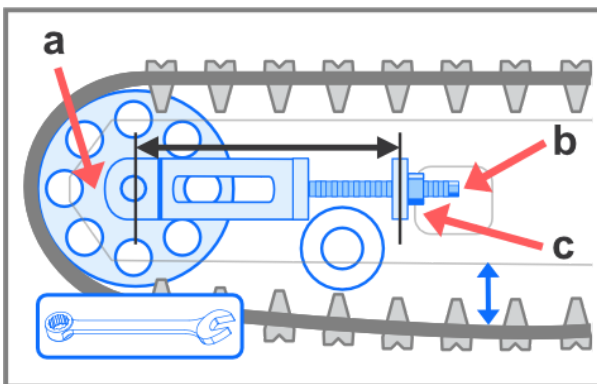

In machines equipped with a screw tensioner use an open ended spanner to undo the 32mm lock nut (c) until there is sufficient space to turn the threaded rod in the desired direction.

Using a 16mm spanner or socket, turn the threaded rod (b) to adjust the idler wheel (a) in or out as required.

Secure the 32mm lock nut when done.

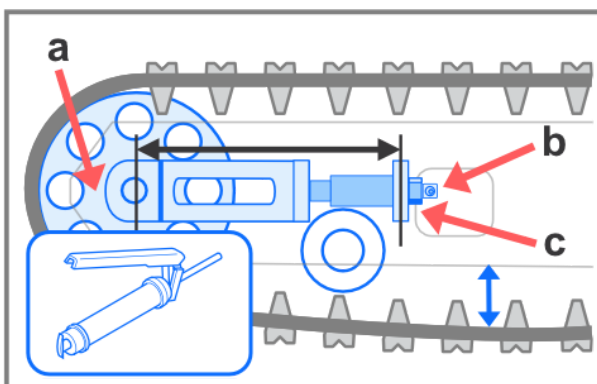

In machines equipped with a grease cylinder increase the tension by injecting grease into the fitting (b) with a grease gun.

To decrease tension, slowly loosen the discharge valve (c) with a spanner. Tighten the grease discharge valve when done.

A tensioner cylinder holds grease under pressure. Follow the correct procedures to avoid injuries with the discharge valve.

## Replacing the crawler track

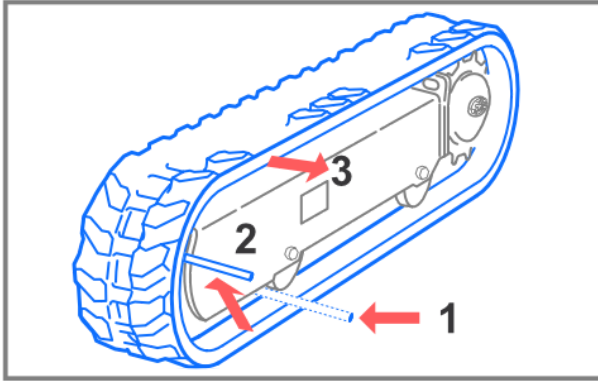

Use the arm and the dozer blade to lift the machine's body.

Release the tension on the idler wheel.

Remove the track following these steps:

- 1) Set an iron pipe in the rubber crawler and turn the sprocket slowly in the reverse direction.
- 2) Turn until the iron pipe is directly between the idler wheel.
- 3) Lift the rubber track of the idler wheel and slide out the track.

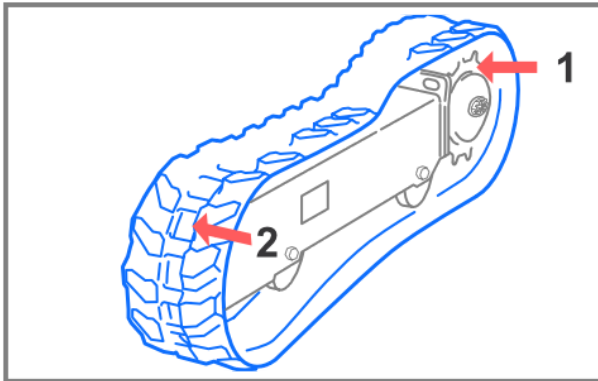

When installing a rubber track check the direction of rotation of the tracks. A track that has a V-shape or angle pattern must be pointing forward towards the idler wheel.

Insert the track following these steps:

- 1) Lift the track over the drive sprocket first.
- 2) Move the track so that it fits over the front idler wheel and align the lugs centers.

Adjust the idler wheel tension. Refer to section "ADJUSTING TRACK TENSION". Check alignment with the track rollers while adjusting the tension.

## Lubrication

See APPENDIX: LUBRICANTS AND FUELS for details on lubricants to use.

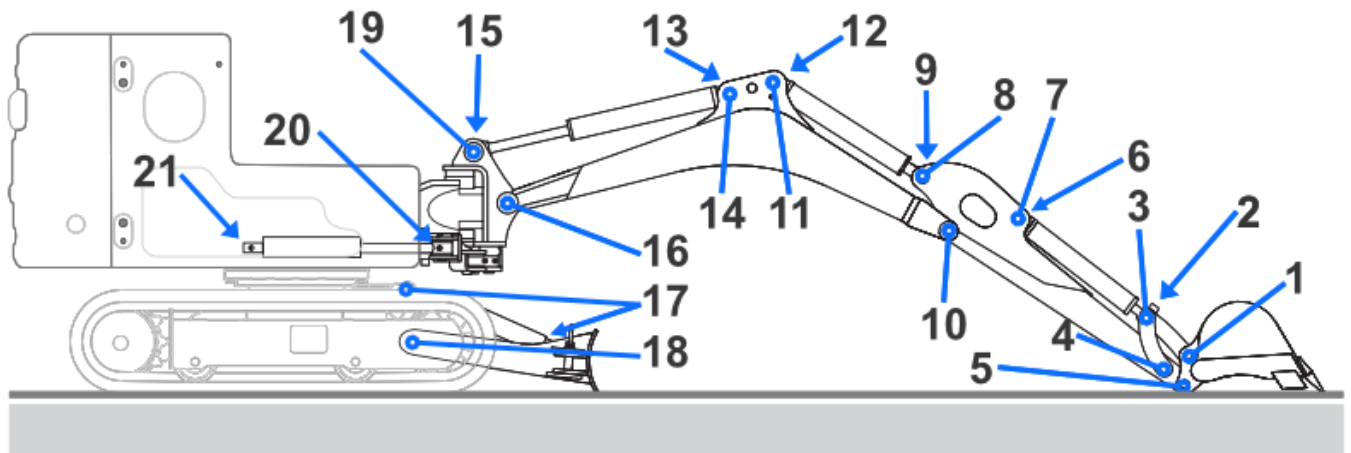
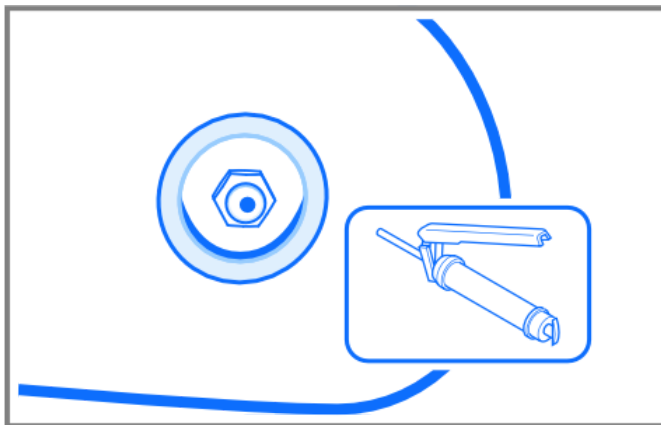

Figure: Lubrication Points

Lower the working equipment to the ground with the boom and arm extended.

Stop the engine.



Use a grease gun to lubricate the grease fittings.

This machine uses metric flush grease fittings. Use a needle nozzle with a zerk grease gun.

Wipe off the excess grease.

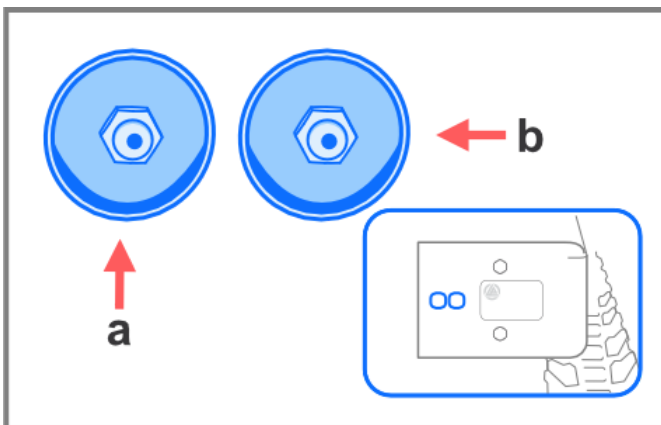

The grease fittings for the slew bearing (a) and the slew motor pinion (b) are located on the front side of the machine carriage on the right side of the boom.

When greasing the slew bearing (a) do a 90° rotation of the upper structure grease the fitting again. Repeat three more times to complete a full rotation.

Wipe off the grease expelled from the slew bearing and grease fitting.

Do not grease the machine with the engine one.



## Inspection of hydraulic hoses



Fittings are manufactured under different standards for their dimensions and tolerances like DIN, BSP, JIC, SAE. Using the wrong fitting will lead to leaks or equipment failure.



This machine may include optional attachments and features that require different hoses and fittings not specified in this document.



When a leak is suspected, never expose yourself to a pressurized hose even when wearing gloves.

Contact with highly pressurized hydraulic fluid can lead to an injection injury where the fluid is trapped beneath your skin. In such an event visit the emergency room immediately.

Hydraulic hoses are listed by their inner diameter (I.D.) and sized to a fitting/adaptor by their outside diameter (O.D.).

Hydraulic components use various hoses and fittings. Refer to appendix "Hoses Reference" for details on each type used.

### Parts and Service Specifications

Hose Specification	EN 857 2SC Min rated pressure of 35mPa.
Type	Synthetic rubber, double steel braid reinforcement
Fittings	DIN 2353 L (@ ~300bar)
Max Hydraulic Oil Temp	~ 200 °F

## Checking the hydraulic oil tank level and replenishing



Hydraulic oil spurts out if caps or connections are removed before the system pressure is released.



Do not allow any dirt or fluids to enter the hydraulic oil tank. Clean surfaces before opening the tank.

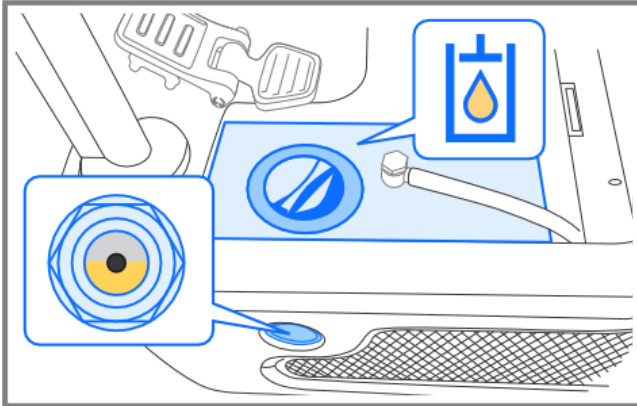

The hydraulic oil level is verified using the sight glass located on the left panel of the machine.

The hydraulic oil tank is located inside the upper structure. To access the tank remove the floor panel in the front of the operator seat.

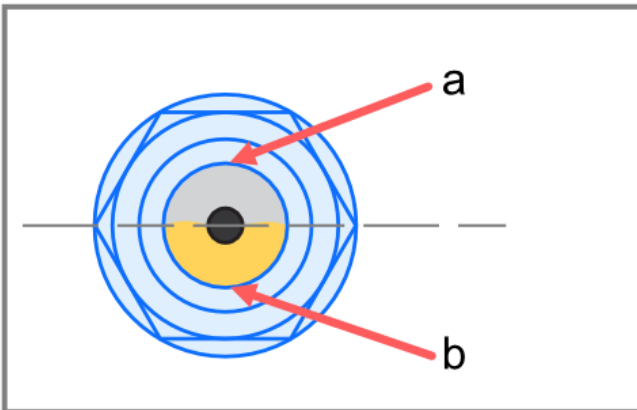

The hydraulic oil level will be dependent on the machine temperature.

When the machine is cool, the proper oil level will be in the middle of the sight glass.

While the machine is hot the oil level may be close to the top or above (a).

Under no circumstances the machine should be operated with the oil level below the bottom of the sight glass (b).

See APPENDIX: LUBRICANTS AND FUELS for details on acceptable hydraulic oil types.

Open the hydraulic tank cap and add oil to the specified level.

Do not replenish hydraulic oil above the middle of the sight glass.

Replace the cap on the hydraulic oil tank.

## Electrical

Disconnect the wiring from the both terminals (+ and -) on the battery before working on the electrical system or doing electric welding.

Always disconnect it from the earth side (-). When connecting, connect the earth side last.

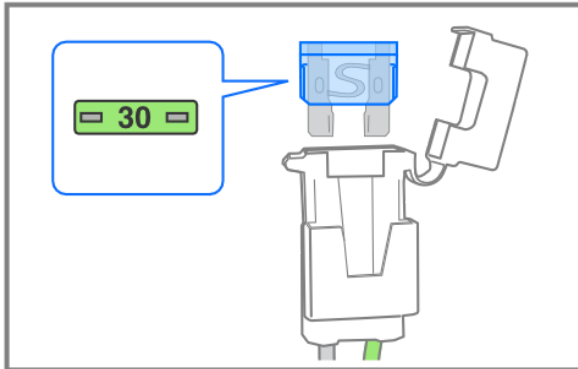

The electrical system is protected by a 30 Amps ATM fuse located under the operator seat. Machines equipped with a cabin heater and fan have a 20 Amps ATM fuse located under the floor panel.

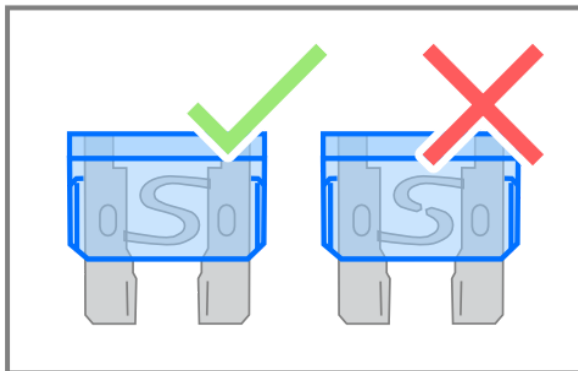









If the engine does not start and the horn does not work, a fuse may be blown. Check for a blown fuse.

Replace a blown fuse with a fuse of the same amperage.

The engine alternator provides 10 amps of current to the machine's loads and to charge the 12v battery.

## Maintenance Schedule

What	Daily	Initial 30 hours	Every 50 hours	Every 100 hours	Every 250 hours
Inspect the fuel level					
Inspect and replenish the engine oil					
Inspect the hydraulic oil tank level and replenish					
Inspect the rubber crawlers					
Inspect for signs or hydraulic oil leakage.					
Inspect for signs or fuel leakage.					
Replace the hydraulic oil return filter					
Inspect and adjust the crawler tension					
Inspect hoses and replace if necessary					
Lubricate the slew motor pinion					
Lubricate the slew bearing					
Grease bushings and pivot pins					
Replace the engine oil and the oil filter					
Inspect the battery fluid level and replenish as required					
Clean or replace the fuel filter					
Clean the engine air filter					

What	Daily	Initial 50 hours	Every 50 hours	Every 100 hours	Every 250 hours
Inspect and clean the main hydraulic relief valve.					
Inspect and clean the solenoid diverter valves.					
Grease the hydraulic control levers with a MOLY GREASE	as necessary				
Inspect fuel tank and drain water and sediment from the fuel tank when necessary.	Every 1000 hours or as necessary in humid or wet conditions				
Replace the engine air cleaner element	Every 1000 hours				
Check and replace stiff or cracked hydraulic hoses.	Every 1000 hours				
Check the bolts and nuts for proper tightening torque.	Every 2000 hours				
Replace the hydraulic oil and clean the suction strainer.  <i>Perform before if hydraulic oil temperatures reach around 140°F periodically as the oil will start to break down and degrade.</i>	Every 2000 hours				

**IMPORTANT:** When operating the machine in harsh environments (with high dust levels, humid/wet or high temperatures), inspection and maintenance should be performed earlier than at the intervals specified on the Maintenance Schedule.

### Operating under a lot of dust, sand, mud and other particles.

Replace grease on all bearings and pivot pins by injecting enough grease to eject old grease.

Particles in particular silica particles from concrete and other aggregates can damage seals and the piston rod. Wipe the hydraulic cylinder rod clean to prevent particles on the rod surface from getting inside the seal.

### Operating under wet or very humid conditions.

Humidity and water can cause rust build up inside the cylinder. Wipe clean the rods often and use water resistance lubricant on the cylinder rod. Humidity can cause excessive condensation in the fuel tank and hydraulic tank.

# APPENDIX: Engine XR Series 25T 13.5 HP

MODELS: XCV-R319-B1-XXXX-01-2024

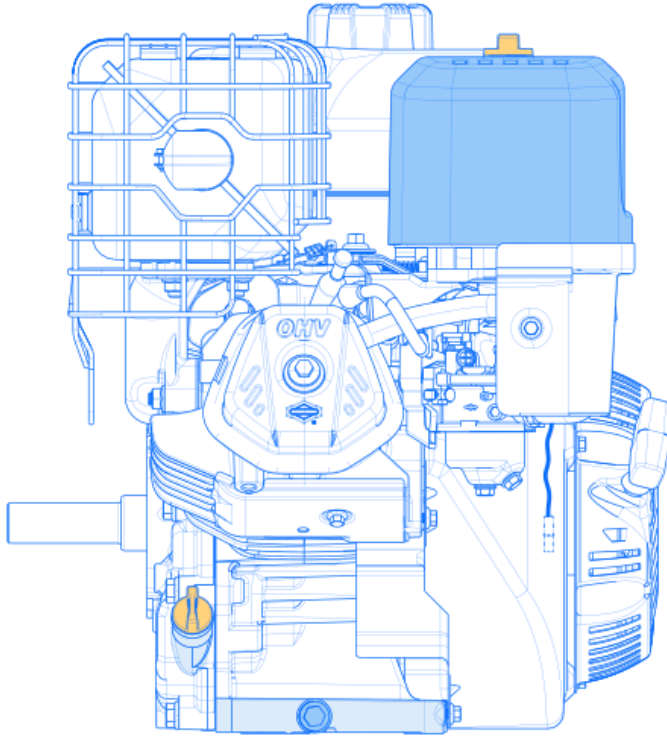

## Briggs & Stratton XR Series 13.5 HP 420cc

Model Number: 25T237-0282-F1

Torque: 21.0 ft-lbs

Displacement: (cc) 420

Single Cylinder, Bore x Stroke (mm) 90 x 66

Manual Choke

Electric Starter

Oil Capacity (L) 1.10

Fuel Type Gasoline

Fuel Tank Capacity 6.5 L

Length (mm) 405

Width (mm) 450

Height (mm) 457

Weight (kg) 31

Dura-Bore® cast iron cylinder sleeve for extended life. PTO ball bearing. Overhead valve design (OHV) for cooler operation and long valve life

## Parts and Service Specifications

Spark Plug Gap	.030 in (,76 mm)
Spark Plug Torque	274 lb-in (31 Nm)
Spark Plug (Resistor)	PN 797235
Spark Plug (Non-Resistor)	PN 798615
Paper Air Filter	PN 592605
Oil Capacity	1.2 L
Fuel Capacity	10 L
Oil Drain Plug	M12 x 1.5

See APPENDIX: LUBRICANTS AND FUELS for details on lubricants and gasoline used on this engine.

## Changing the engine oil

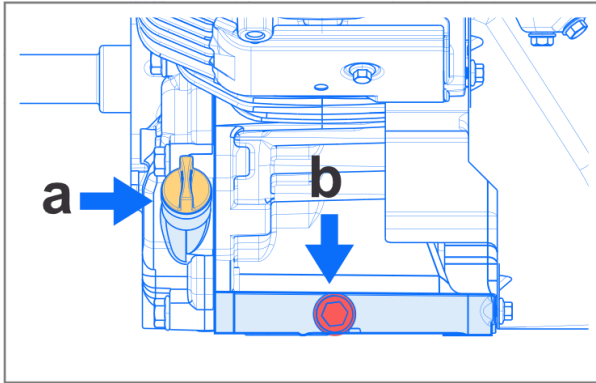

Clean the area around the oil dipstick (a)(yellow), Drain Plug (b)(red) of dirt that can accidentally get into the oil sump.

Used oil is a hazardous waste product and must be discarded correctly. Do not discard with household waste. Contact your local authorities, service center, or recycling facilities for safe disposal or recycling.

See the **Schedule Maintenance** section for additional information on engine oil requirements.

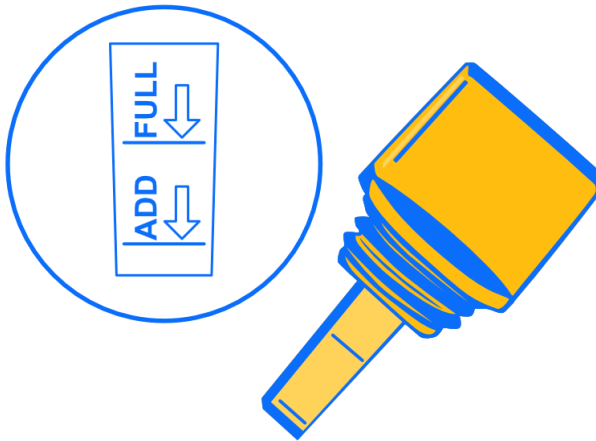

### Check oil level

Remove the dipstick (a) and check the oil level. The correct oil level is at the top of the full indicator on the dipstick.

### Drain Oil

Remove the oil drain plug (B).

Drain the oil into an approved container.

Install and tighten the oil drain plug (B).

### Add Oil

Remove the dipstick (A). Use a cloth to remove oil from the dipstick.

Slowly add oil into the engine. Do not add too much oil.

Install the dipstick. Do not turn or tighten the dipstick. Wait one minute and check the oil level again. Make sure that the oil level is correct.

## Servicing the engine air filter.

### C Air Filter

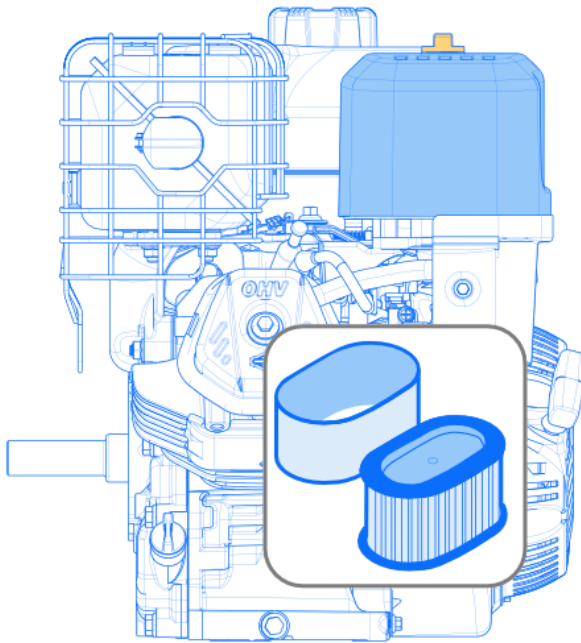

See the Schedule Maintenance section for additional information on air filter requirements.

Loosen the fastener of the air filter case. Remove the cover (C).



To loosen debris, lightly tap the filter on a hard surface. If the filter is dirty, replace it with a new filter.

Using pressurized air to clean the filter may result in damage to the filter.



Install the cover with the fasteners. Make sure that the fasteners are tight.

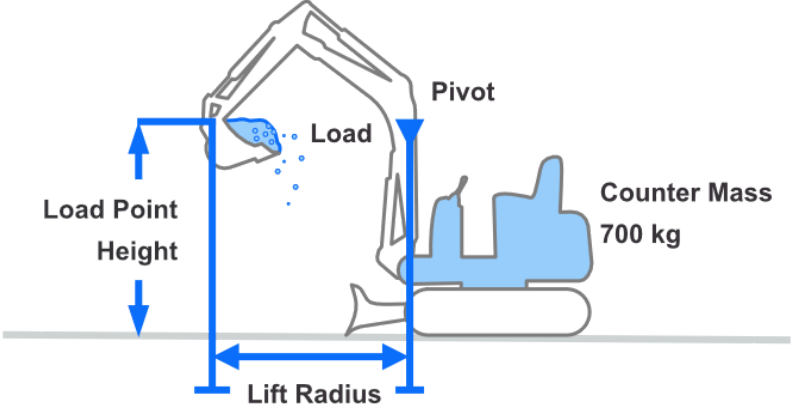

# APPENDIX: Lift Capacities

<b>WARNING</b>				XCV-R319-B1-XXXX-01-2024						
				BOOM: 1480 mm ARM: 800 mm SHOE: 915 mm				RATED PRESSURE: 18 Mpa COUNTER MASS: 700 Kg		
<p>Do not lift or hold any load that exceeds these ratings at their specified load radii and height.</p> <p>Total rated load is shown. The weight of all lifting devices must be deducted to determine the net load that can be lifted.</p>										
										
Lift Point Height (m)	Front Loading			Side Loading						
	Lift Radius			Lift Radius						
	2.5 m	2 m	1.5 m	2.5 m	2 m	1.5 m				
1 m	280 kg	350 kg	460 kg	120 kg	160 kg	240 kg				
0.5 m	320 kg	450 kg	570 kg	130 kg	180 kg	260 kg				
-1 m	-	480 kg	680 kg	-	205 kg	285 kg				

# APPENDIX: Lubricants and Fuels

Where	Type
Working equipment	<b>NLGI No. 2</b>
Slew bearing	<i>EP-2 (Extreme Pressure Grease, Calcium Sulfonate) (may use optional 5% molybdenum disulfide)</i>
Slew motor pinion	 For wet and humid conditions consider an HD-2 (Heavy Duty, Calcium Sulfonate) grease with a higher water washdown protection.
Levers	Lithium based grease
Hydraulic Oil	<p>Use high load (HL) mineral oil (Schadenskraftstufe <math>\geq 5</math>).</p> <p>Select the viscosity grade (VG) according to the operating conditions:</p> <p><b>ISO VG 46</b> Normal conditions from 0 °F to 100 °F</p> <p><b>ISO VG 68</b> Hotter temperatures up to 140 °F.</p> <p><b>ISO VG 32</b> Cold temperatures down to -20 °F with higher viscosity.</p> <p> Use an Anti-Wear (AW) formula for added protection.</p>
Engine Oil: BS XR25T	<p>Select according to operating conditions:</p> <p><b>10W-30</b> From 40° F to 100° F. <i>Above 80° F (27° C) increased oil consumption may occur. Check the oil level frequently.</i></p> <p><b>Synthetic 15W-50</b> From 20° F and above. <i>Recommended for high temperatures.</i></p> <p><b>5W-30</b> From 40° F and below.</p> <p><b>Synthetic 15W-50</b> From 100° F and below.</p> <p><b>SAE-30</b> From 40° F to 100° F. <i>Below 40 °F (4 °C) hard starting may occur.</i></p> <p><i>High-quality detergent oils are permitted if classified for service SF, SG, SH, SJ or higher.</i></p> <p>Do not use special additives.</p>
Engine Gasoline: BS XR25T	<p>Use clean, fresh, unleaded gasoline.</p> <p><b>Do not use E15 and E85.</b></p> <p>Gasoline must be rated at 87 octane/87 AKI (91 RON) or higher. At higher</p>

altitudes (over 5,000 feet) a lower octane may be used.

Gasoline with up to 10% ethanol (E10) is permitted.



Do not mix oil in gasoline or change the engine to operate on alternate fuels.

# APPENDIX: Consumables and Components

MACHINE: XCV-R319-B1-SBC2-01-2024

Rev: April 2024

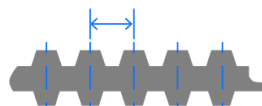
See maintenance schedule for details on component replacement requirements.

Item	Replacement Details		
BS XR 25T: Air Filter	PN 799818, Briggs & Stratton		
BS XR 25T: Spark Plug	PN 798615, Briggs & Stratton		
BS XR 25T: Fuel Filter	PN 394358S, Briggs & Stratton or Replacement Filter OD 1/4", 75 micron or better		
BS XR 25T: Fuel Line	PN 590374, Briggs & Stratton or Replacement hoses ID 1/4" (6.3mm), Reinforced Nitrile Black Rubber, SAE 30R14		
Main Fuse	30A (green), ATO Blade Fuse. Located under the starter key cover.		
Cabin Heater/Fan Fuse	20A (yellow), ATO Blade Fuse. Located under the foot panel.		
Ignition Relay	ISO Standard 12V, 5 Pole, Type B (30 TO 87a N.C. 30 TO 87 N.O)		
Battery	Group Size: B24-R Model 55B24R (JIS Battery Code) (N45) Calcium/Lead Acid, 12V, 45AH, CCA: 300, RC 60 min Size: 238mm x 128mm x 202mm (L x W x H) Terminal: SAE - Type A (standard), Positive Right		
<p>Return Line Hydraulic Oil Filter Element.</p> <p>Filtrates the hydraulic oil flowing back to the tank on the return lines.</p> <p>Location: Floor panel, from DCV return line to Hydraulic Tank.</p>	<p>LEEMIN SPX-0608X10, SPX08X10</p> <p>Thread Size: 1"-12 UNF</p> <p>OD Top: 93mm</p> <p>Length: 135mm</p> <p>Gasket: G401</p> <p>Filtration: 10 micron</p>		
Crawler Rubber Tracks	Width	Pitch	Num Links
	180mm	72mm	32
			
Hydraulic Geared Pump	Mgf. Parker		

	<p>Part No. CBT-E306R2HR1  3 gear modulus with 6 mL/r displacement.  Pressure:  Nominal: 20 mPa  Max: 25 mPa  Inlet: M20 x 1.5  Outlet: M18 x 1.5</p>
Hydraulic Travel Orbital Motor	<p>White Label OEM Replacement for Eaton 4000 Travel Motor 315  Wheel mount</p>
Arm 3-Way Valve for attachments	<p>Model: KHB3K Ball Valve, L-Bore  Ports Threads: G3/8, BSPP    Op. Pressure: 50 MPa  Flow Rate: 30 L/min</p>
<p>Solenoid Diverter Valve</p> <p>Switches hydraulic flow from swing motor to boom swing.</p> <p>Located: Right side engine compartment.</p>	<p>Model: MOP-06, 12V  Ports Threads: G3/8, BSPP  Drain Port: G1/4, BSPP    Op. Pressure: 25 MPa  Flow Rate: 50 L/min  Oil Requirements: NAS1638 class 9/ISO4406 class    Mounting:  M6 screw holes  M6 x 70mm hex socket head screw w/ 5mm</p>

## APPENDIX: Emissions Control

The emissions control system may include parts such as the carburetor or fuel injection system, the ignition system, catalytic converter, fuel tanks, fuel lines (for liquid fuel and fuel vapors), fuel caps, valves, canisters, filters, clamps and other associated components. Also included may be hoses, belts, connectors, and other emission related assemblies.

Emission compliance is subject to following the engines maintenance schedule as provided by the manufacturer and use of approved replacement parts.

The engine and engine documentation will provide the current Emission Labels and related information.

An excavator with a Briggs & Stratton engine is certified to meet the United States Environmental Protection Agency (US EPA) Phase 2 or Phase 3 emissions standards depending on the engine model installed in the excavator.

The Emissions Compliance Period referred to on the Emissions Compliance label indicates the number of operating hours for which the engine has been shown to meet Federal emissions requirements.

Engine	Year	Class	Fuel	Operating Hours	Emissions
RJDGS.4202UA	2024	Non Handheld Class II	E10, Gasoline	250 Hours	HC+NOx : 8.0 CO : 610

See additional information provided with your machine or contact EXCAV for current emissions information.

### USA Federal Clean Air Act

The Federal Clean Air Act Section 203.a (3) prohibits the removal of air pollution control devices or the modification of an EPA-certified non-road engine to a non certified configuration.

The Federal regulations implementing the Clean Air Act for non-road engines, 40 CFR 89.1003(a)(3)(i), reads as follows:

The following acts and the causing thereof are prohibited:  
For a person to remove or render inoperative a device or element of design installed on or in a non- road engine vehicle or equipment in compliance with the regulations under this part prior to its sale and delivery to the ultimate purchaser or for a person knowingly to remove or render inoperative such a device or element of design after the sale and delivery to the ultimate purchaser.

The law prescribes a fine of up to \$2,750 USD for each violation.



Operating, servicing and maintaining a passenger vehicle or off road vehicle can expose you to chemicals including engine exhaust, carbon monoxide, phthalates, and lead, which are known to the State of California to cause cancer and birth defects or other reproductive harm. To minimize exposure, avoid breathing exhaust, do not idle the engine except as necessary, service your vehicle in a well-ventilated area and wear gloves or wash your hands frequently when servicing your vehicle. For more information go to [www.P65Warnings.ca.gov/passenger-vehicle](http://www.P65Warnings.ca.gov/passenger-vehicle).



## APPENDIX: Units of Measurements

Force & Pressure	
1 lb/in	175.1268369864 N/m
1 bar	100000 Pa (pascals)
1 bar	14.5037 psi
1 psi	0.0689475729 bar
1 psi	6894.7572 Pa
1 psi	6894757.293 mPa
1 mPa (millipascal)	0.001 pascal

Displacement (Flow)	
1 cc	1 cubic cm (cm <sup>3</sup> )
1 mL	1 cubic cm (cm <sup>3</sup> )



## APPENDIX: Torque Values



**IMPORTANT:** Use the torque wrench to check the torques of bolts and nuts!

Standard torque values for metric bolts and nuts			
Thread dimensions	Standard torque (N.m)	Thread dimensions	Standard torque (N.m)
M6	12±3	M14	160±30
M8	28±7	M16	240±40
M10	55±10	M20	460±60
M12	100±20	M30	1600±200

Item	Torque
M16 bolts fixing the traveling motor	252±39.2
M16 bolts fixing the sprocket	252±39.2
M20 bolts fixing the slewing bearing	570±60
M20 bolts fixing the swing mechanism	570±60
Grease discharge valve	177 Nm