

MIN EXCAVATOR R319



Tough muscle to get things done...

Unexpected versatility and exceptional performance in a small footprint to maximize maneuverability in confined spaces.

This machine is perfect for independent contractors, plumbers, electricians, landscapers, farmers, and anyone looking for a cost-effective workhorse that is easy to maintain and operate.

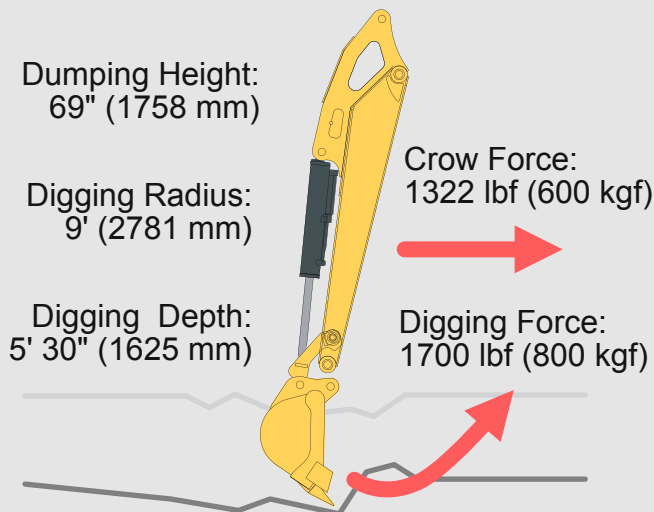

Net Power:
9.6 kW 13 hp

Hydraulics
Pressure: 18 mPa (2610 psi)
Flow rate: 21.6 L/min

Climbing Ability:
17° (30%)

Ground specific pressure:
23.43 Kpa

Standard Digging Bucket
Size: 10" (277 mm)
Capacity: 0.14 m3

Width: 36" (914 mm)
Height: 87.05" (2211 mm)
Weight: 1869 lb (848 kg)



Designed to stand its ground!

Spring guards and poly shields used to protect hose lines from abrasions and work conditions.

Protected hoses, routed inside the boom.

Tough one-piece forged cylinders deliver smooth movements with the best lifespan.

Secure and reliable 3-way valves standard on all models.

Superior hardened steel pins.

Easy to change attachments.

Rigid and tough buckets to get things done.

Compatible with common 90mm attachments and tools.

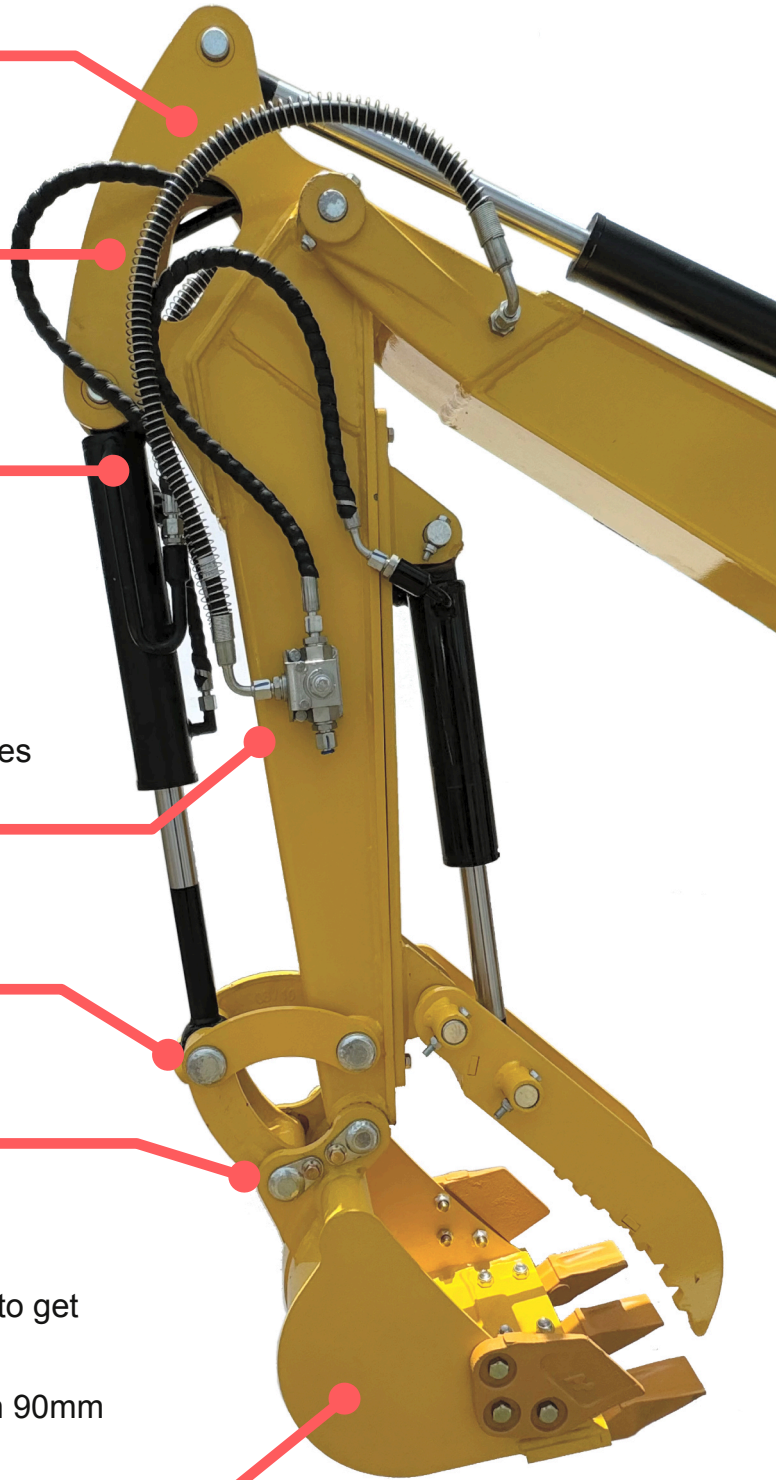

Built to deliver the power you need.



Tough construction with thick 9.5mm high tensile strength carbon steel, solid undercarriage and A class welding.

Exceptional working range in a compact package designed for safety.

The boom cylinder on top increases the reach and add security without adding weight.

Operate the bucket closer to the dozer blade.

A swing boom lets you work in even tighter spaces.



Trust the robust Briggs & Stratton XR25T 13.5HP engine to provide exceptional performance and fuel economy, with reliable service information and accessible spare parts.

Work Tools

A range of tools is available to get the most of your mini excavator.

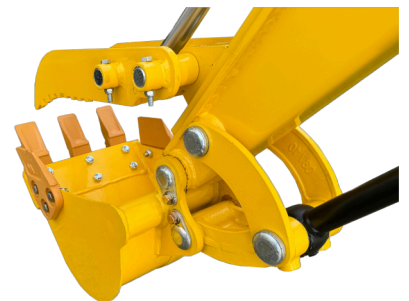
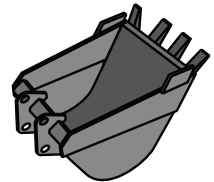
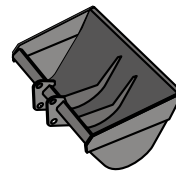
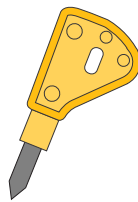

Work ready!

✓ High visibility open canopy with operator protection.

✓ Easy transport

✓ Working lamp on the boom.

✓ Top mounted boom cylinder

✓ Swing Boom

✓ 90mm compatible attachments.

✓ Reliable hydraulic components

✓ All models are ready for attachments.

✓ Tools Pedals

✓ Tough single piece undercarriage. Precision automated robot welds.

✓ Heat shielding and dissipation.

✓ Hydraulic oil filtration

✓ Lowest cost to service and operate

✓ Reduced vibrations.





Sales and Support

+1 787-464-3264

Aguadilla, Puerto Rico, USA
<https://miniexcav.com>

